

IVX-1000 USER

14th Gen. Intel® Core™ i9/i7/i5/i3 Fanless AI Computing System with
NVIDIA® MXM GPU Graphics, High Performance Expandable

Manual

Record of Revision

Version	Date	Page	Description	Remark
1.00	2023/05/02	All	Official Release	
1.10	2023/08/25	22	Update	
1.20	2023/10/30	All	Update	
1.30	2024/01/10	4, 6, 7	Update	
2.00	2024/05/28	v, 1, 2, 3, 5, 7	Update	
2.10	2024/07/10	All	Update	
2.20	2024/09/24	All	Update	

Disclaimer

This manual is released by Vecow Co., Ltd. for reference purpose only. All product offerings and specifications are subject to change without prior notice. Vecow Co., Ltd. is under no legal commitment to the details of this document. Vecow shall not be liable for direct, indirect, special, incidental, or consequential damages arising out of the use of this document, the products, or any third party infringements, which may result from such use.

Declaration of Conformity

FCC This equipment has been tested and found to comply with the limits for a Class A digital device, pursuant to part 15 of the FCC Rules. These limits are designed to provide reasonable protection against harmful interference when the equipment is operated in a commercial environment. This equipment generates, uses, and can radiate radio frequency energy, and if it is not installed and used in accordance with the instruction manual, it may cause harmful interference to radio communications. Operation of this equipment in a residential area is likely to cause harmful interference in which case the user will be required to correct the interference at his own expense.

CE The products described in this manual comply with all applicable European Union (CE) directives if it has a CE marking. For computer systems to remain CE compliant, only CE-compliant parts may be used. Maintaining CE compliance also requires proper cable and cabling techniques.

Copyright and Trademarks

This document contains proprietary information protected by copyright. No part of this publication may be reproduced in any form or by any means, electric, photocopying, recording or otherwise, without prior written authorization by Vecow Co., Ltd. The rights of all the brand names, product names, and trademarks belong to their respective owners.

Order Information

Part Number	Description
IVX-1000	1 GigE LAN, 1 2.5G LAN, 8 M12 2.5G LAN w/4 PoE+, 4 Isolated COM, 16 Isolated DIO, 2 SSD Tray
IVX-1000 ICY	1 GigE LAN, 1 2.5G LAN, 8 M12 2.5G LAN w/4 PoE+, 4 Isolated COM, 16 Isolated DIO, 6 SSD Tray, with optional UPS

Order Accessories

Part Number	Description
DDR5 48G	Certified DDR5 48GB 5600MHz RAM
DDR5 32G	Certified DDR5 32GB 4800/5600MHz RAM
DDR5 24G	Certified DDR5 24GB 5600MHz RAM
DDR5 16G	Certified DDR5 16GB 4800/5600MHz RAM
DDR5 8G	Certified DDR5 8GB 4800/5600MHz RAM
PWA-180WB	180W, 24V, 90V AC to 264V AC Power Adaptor with 3-pin Terminal Block (7.62mm pitch)
PWA-330WB	330W, 24V, 90V AC to 264V AC Power Adaptor with 3-pin Terminal Block (7.62mm pitch)
TMK2-20P-100	Terminal Block 20-pin to Terminal Block 20-pin Cable, 100cm
TMK2-20P-500	Terminal Block 20-pin to Terminal Block 20-pin Cable, 500cm
TMB-TMBK-20P	Terminal Board with One 20-pin Terminal Block Connector and DIN-Rail Mounting
Rack Mount	2U/4U Rackmount Kit
M.2 Storage Module	M.2 Key M Storage Module
5G Module	5G Module with Antenna
4G Module	4G/GPS Module with Antenna
WiFi & Bluetooth	WiFi & Bluetooth Module with Antenna

CPU List

Series	CPU	Cores	GHz	TDP (W)	ECC
Intel® Core™ (14th Gen)*	i9-14900	24	5.8	65	Y
	i7-14700	20	5.4		
	i5-14500	14	5		
	i3-14100	4	4.7		
	i9-14900T	24	5.5	35	
	i7-14700T	20	5.2		
	i5-14500T	14	4.8		
	i3-14100T	4	4.4		
Intel® Core™ (13th Gen)	i9-13900E	24	5.2	65	Y
	i7-13700E	16	5.1		
	i5-13500E	14	4.6		
	i3-13100E	4	4.4		
	i9-13900TE	24	5	35	
	i7-13700TE	16	4.8		
	i5-13500TE	14	4.5		
	i3-13100TE	4	4.1		
Intel® Core™ (12th Gen)	i9-12900E	16	5	65	Y
	i7-12700E	12	4.8		
	i5-12500E	6	4.5		
	i3-12100E	4	4.2		
	i9-12900TE	16	4.8	35	
	i7-12700TE	12	4.7		
	i5-12500TE	6	4.3		
	i3-12100TE	4	4		

* 14th Gen support PC Client use condition only.

Table of Contents

CHAPTER 1	GENERAL INTRODUCTION	1
1.1	Overview	1
1.2	Features	2
1.3	Product Specification	3
1.3.1	Specifications of IVX-1000	3
1.3.2	Specifications of IVX-1000 ICY	5
1.4	Supported CPU List	7
1.5	System Configuration Recommendation	7
1.6	Mechanical Dimension	8
1.6.1	Dimensions of IVX-1000	8
1.6.2	Dimensions of IVX-1000 ICY	8
CHAPTER 2	GETTING TO KNOW YOUR IVX-1000	9
2.1	Packing List of IVX-1000/IVX-1000 ICY	9
2.1.1	Packing List of IVX-1000	9
2.1.2	Packing List of IVX-1000-ICY	10
2.2	Front Panel I/O & Functions	11
2.3	Main Board Expansion Connectors	24
2.4	Main Board Jumper Settings	39
2.5	Ignition Control	43

CHAPTER 3	SYSTEM SETUP	46
3.1	How to Open Your IVX-1000	46
3.2	Installing CPU	47
3.3	Installing DDR5 SO-DIMM Modules	50
3.4	Installing Mini PCIe Card	54
3.5	Installing Nano SIM Card	55
3.6	Installing SSD/HDD	56
3.7	Installing M.2	60
3.8	Installing Antenna Cable	63
3.9	Mount Your IVX-1000	64
CHAPTER 4	BIOS AND DRIVER	66
4.1	BIOS Setup	66
4.2	Main Menu	67
4.3	Advanced Function	68
4.4	Chipset Function	74
4.5	Security Function	78
4.6	Boot Function	80
4.7	Save & Exit	80
APPENDIX A	: Isolated DIO Guide	81
APPENDIX B	: Software Functions	99
APPENDIX C	: RAID Functions	104
APPENDIX D	: Power Consumption	109
APPENDIX E	: Supported Memory & Storage List	115

1

GENERAL INTRODUCTION

1.1 Overview

Vecow IVX-1000 Series is a Workstation-grade Fanless AI Computing System. The series is based on 14th Gen Intel® Core™ processor with Intel® R680E PCH and supports DDR5 5200MHz SO-DIMM with up to 96GB of memory. Featuring compact NVIDIA® Quadro® MXM graphics, IVX-1000 Series delivers outstanding AI computing productivity and provides solutions for In-Vehicle applications, including ADAS, Mobile Communication, Public Security, and any AIoT/Industry 4.0 applications.

Vecow IVX-1000 Series offers a wide range of rugged I/O connectivity, including 8 independent 2.5GigE LAN M12 X-coded with 4 IEEE 802.3at PoE+, 1 A-coded M12 USB, 4 Isolated COM RS-232/422/485, 2 SIM card sockets, as well as M.2 to allow flexible expansions and up to 6 front-access 2.5" SSD/HDD tray. The system features a fanless design, supports -25°C to 75°C extended operating temperature and provides 16V to 160V DC power input with 4kV DC Isolation, up to 500W surge protection, software ignition power control and UPS.

Vecow IVX-1000 Series leverage the latest MXM graphics capabilities and facilitates AI computing productivity. The EN50155: 2017 compliant IVX-1000 Series offers rail solution providers the must-have features and ensure rolling stock applications operate efficiently, reliably and safely.

1.2 Features

- Workstation-grade Platform : Intel® Core™ i9/i7/i5/i3 Processor (14th gen, codename : RPL-S Refresh/RPL-S/ADL-S) running with Intel® R680E PCH supports max 65W TDP CPU
- Optional supports outstanding AI computing productivity by advanced and compact NVIDIA® Quadro® MXM graphics
- 16V to 160V DC Power Input with 4kV DC Isolation, up to 500V Surge Protection, Software Ignition Power Control, optional UPS supported
- Fanless design for railway in-vehicle applications, fully compliant with EN50155 : 2017
- 8 Independent 2.5GigE LAN M12 X-coded
- Up to 6 front-access 7mm to 15mm height SSD/HDD Tray
- Supports Intel® vPro, TCC, Time-Sensitive Networking (TSN), and TPM 2.0

1.3 Product Specification

1.3.1 Specifications of IVX-1000

System	
Processor	<ul style="list-style-type: none"> • 24-core Intel® Core™ i9/i7/i5/i3 Processor (14th gen, Raptor Lake-S Refresh) • 24-core 13th Gen Intel® Core™ i9/i7/i5/i3 Processor (Raptor Lake-S) • 16-core 12th Gen Intel® Core™ i9/i7/i5/i3 Processor (Alder Lake-S)
Chipset	Intel® R680E Chipset
BIOS	AMI
SIO	IT8786E
Memory	<ul style="list-style-type: none"> • 2 DDR5 5200MHz • Up to 96GB • 2 262-pin SO-DIMM Socket
I/O Interface	
Serial	4 Isolated COM RS-232/422/485
USB	<ul style="list-style-type: none"> • 4 USB 3.2 Gen2 • 1 A-coded M12 USB 2.0 with 2-port signal
Isolated DIO	16 Isolated DIO : 8 DI, 8 DO
LED	Power, HDD, PoE, Wireless
SIM Card	2 External SIM Card Sockets
RTC Battery	Front-access RTC Battery
Expansion	
Mini PCIe	1 Mini PCIe Socket for PCIe/USB/SIM Card/Optional mSATA
M.2	<ul style="list-style-type: none"> • 1 M.2 Key B Socket (3052/2280, PCIe/USB3, default/USB 2) • 1 M.2 Key E Socket (2230, PCIe/USB)
SUMIT	2 SUMIT Slot (Optional)
Graphics	
Graphics Processor	<ul style="list-style-type: none"> • Intel® UHD Graphics 770/730 driven by Intel® X^e Architecture • Independent MXM Graphics : By request
Interface	<ul style="list-style-type: none"> • 1 VGA : Up to 1920 x 1200 @ 60Hz • 2 HDMI : Up to 1920 x 1080 @ 60Hz • 2 DisplayPort : Up to 4096 x 2304 @ 60Hz (By requested MXM)
Storage	
SATA	2 SATA III (6Gbps) support software RAID 0, 1
mSATA	1 SATA III (Mini PCIe Type, 6Gbps)
M.2	1 M.2 Key M Socket (2280, PCIe x4)
Storage Device	2 Front-access 2.5"SSD/HDD Tray
Audio	
Audio Codec	Realtek ALC888S-VD, 7.1 Channel HD Audio
Audio Interface	1 Mic-in, 1 Line-out

Ethernet	
LAN 1	Intel® I219LM GigE LAN supports iAMT
LAN 2	Intel® I226 2.5GigE LAN supports TSN
LAN 3 to LAN 6	Intel® I226 2.5GigE LAN, X-Coded M12 Connector
LAN 7 to LAN 10	2.5GigE IEEE 802.3at PoE+ by Intel I226, X-Coded M12 Connector (up to 25.5W/48V each port, total power be supported depends on system config.)
Power	
Input Voltage	DC 16V to 160V, Max. support 200W
Power Interface	3-pin Terminal Block : V+, V-, Frame Ground
Ignition Control	16-mode Software Ignition Control
Remote Switch	3-pin Terminal Block
Isolation	4kV DC
Surge Protection	0.5kV DC 8/20us Surge
Others	
TPM	Infineon SLB9670 supports TPM 2.0, SPI Interface
Watchdog Timer	Reset : 1 to 255 sec./min. per step
Smart Management	Wake on LAN, PXE supported
HW Monitor	Monitoring temperature, voltages. Auto throttling control when CPU overheats.
Software Support	
OS	Windows 10, Linux
Mechanical	
Dimension (W x D x H)	360mm x 228mm x 88mm (14.2" x 8.9" x 3.5")
Weight	7.1 kg (15.65 lb)
Mounting	<ul style="list-style-type: none"> • Wallmount by mounting bracket • Rackmount (Optional)
Environment	
Operating Temperature (with air flow)	35W TDP CPU without GPU : -25°C to 75°C (-13°F to 167°F) 35W TDP CPU with <50W GPU : -25°C to 55°C (-13°F to 131°F) 65W TDP CPU without GPU : -25°C to 65°C (-13°F to 149°F) 65W TDP CPU with <50W GPU : -25°C to 45°C (-13°F to 113°F)
Storage Temperature	-40°C to 85°C (-40°F to 185°F)
Humidity	5% to 95% humidity, non-condensing
Relative Humidity	95% @75°C
Shock/Vibration	<ul style="list-style-type: none"> • IEC 61373 : 2010 • Railway Applications : Rolling Stock Equipment, Shock and Vibration Test
EMC	CE, FCC, EN50155, EN50121-3-2

1.3.2 Specifications of IVX-1000 ICY

System	
Processor	<ul style="list-style-type: none"> • 24-core Intel® Core™ i9/i7/i5/i3 Processor (14th gen, Raptor Lake-S Refresh) • 24-core 13th Gen Intel® Core™ i9/i7/i5/i3 Processor (Raptor Lake-S) • 16-core 12th Gen Intel® Core™ i9/i7/i5/i3 Processor (Alder Lake-S)
Chipset	Intel® R680E Chipset
BIOS	AMI
SIO	IT8786E
Memory	<ul style="list-style-type: none"> • 2 DDR5 5200MHz • Up to 96GB • 2 262-pin SO-DIMM Socket
I/O Interface	
Serial	4 Isolated COM RS-232/422/485
USB	<ul style="list-style-type: none"> • 4 USB 3.2 Gen2 • 1 A-coded M12 USB 2.0 with 2-port signal
Isolated DIO	16 Isolated DIO : 8 DI, 8 DO
LED	Power, HDD, PoE, Wireless
SIM Card	2 External SIM Card Sockets
RTC Battery	Front-access RTC Battery
Expansion	
Mini PCIe	1 Mini PCIe Socket for PCIe/USB/SIM Card/Optional mSATA
M.2	<ul style="list-style-type: none"> • 1 M.2 Key B Socket (3052/2280, PCIe/USB3, default/USB 2) • 1 M.2 Key E Socket (2230, PCIe/USB)
SUMIT	2 SUMIT Slot (Optional)
Graphics	
Graphics Processor	<ul style="list-style-type: none"> • Intel® UHD Graphics 770/730 driven by Intel® X^e Architecture • Independent MXM Graphics : By request
Interface	<ul style="list-style-type: none"> • 1 VGA : Up to 1920 x 1200 @ 60Hz • 2 HDMI : Up to 1920 x 1080 @ 60Hz • 2 DisplayPort : Up to 4096 x 2304 @ 60Hz (By requested MXM)
Storage	
SATA	6 SATA III (6Gbps) support software RAID 0, 1, 5, 10
mSATA	1 SATA III (Mini PCIe Type, 6Gbps)
M.2	1 M.2 Key M Socket (2280, PCIe x4)
Storage Device	6 Front-access 2.5"SSD/HDD Tray (15mm in height)
Audio	
Audio Codec	Realtek ALC888S-VD, 7.1 Channel HD Audio
Audio Interface	1 Mic-in, 1 Line-out

Ethernet	
LAN 1	Intel® I219LM GigE LAN supports iAMT
LAN 2	Intel® I226 2.5GigE LAN supports TSN
LAN 3 to LAN 6	Intel® I226 2.5GigE LAN, X-Coded M12 Connector
LAN 7 to LAN 10	2.5GigE IEEE 802.3at PoE+ by Intel I226, X-Coded M12 Connector (up to 25.5W/48V each port, total power be supported depends on system config.)
Power	
Input Voltage	DC 16V to 160V, Max. support 200W
Power Interface	3-pin Terminal Block : V+, V-, Frame Ground
Ignition Control	16-mode Software Ignition Control
Remote Switch	3-pin Terminal Block
Isolation	4kV DC
Surge Protection	0.5kV DC 8/20us Surge
UPS (IVX-1000 ICY)	<ul style="list-style-type: none"> • Optional supports 3 stackable 18650 Li Batteries (2.5A/h) • Optional supports Super Cap
Others	
TPM	Infineon SLB9670 supports TPM 2.0, SPI Interface
Watchdog Timer	Reset : 1 to 255 sec./min. per step
Smart Management	Wake on LAN, PXE supported
HW Monitor	Monitoring temperature, voltages. Auto throttling control when CPU overheats.
Software Support	
OS	Windows 10, Linux
Mechanical	
Dimension (W x D x H)	360mm x 228mm x 171mm (14.2" x 8.9" x 6.7")
Weight	10.6 kg (23.43 lb)
Mounting	<ul style="list-style-type: none"> • Wallmount by mounting bracket • Rackmount (Optional)
Environment	
Operating Temperature (with air flow)	35W TDP CPU without GPU : -25°C to 75°C (-13°F to 167°F) 35W TDP CPU with <50W GPU : -25°C to 55°C (-13°F to 131°F) 65W TDP CPU without GPU : -25°C to 65°C (-13°F to 149°F) 65W TDP CPU with <50W GPU : -25°C to 45°C (-13°F to 113°F)
Storage Temperature	-40°C to 85°C (-40°F to 185°F)
Humidity	5% to 95% humidity, non-condensing
Relative Humidity	95% @75°C
Shock	<ul style="list-style-type: none"> • IEC 61373 : 2010 • Railway Applications : Rolling Stock Equipment, Shock and Vibration Test
EMC	CE, FCC, EN50155, EN50121-3-2

1.4 Supported CPU List

Series	CPU	Cores	GHz	TDP (W)	ECC
Intel® Core™ (14th Gen)*	i9-14900	24	5.8	65	Y
	i7-14700	20	5.4		
	i5-14500	14	5		
	i3-14100	4	4.7		
	i9-14900T	24	5.5	35	
	i7-14700T	20	5.2		
	i5-14500T	14	4.8		
	i3-14100T	4	4.4		
Intel® Core™ (13th Gen)	i9-13900E	24	5.2	65	
	i7-13700E	16	5.1		
	i5-13500E	14	4.6		
	i3-13100E	4	4.4		
	i9-13900TE	24	5	35	
	i7-13700TE	16	4.8		
	i5-13500TE	14	4.5		
	i3-13100TE	4	4.1		
Intel® Core™ (12th Gen)	i9-12900E	16	5	65	
	i7-12700E	12	4.8		
	i5-12500E	6	4.5		
	i3-12100E	4	4.2		
	i9-12900TE	16	4.8	35	
	i7-12700TE	12	4.7		
	i5-12500TE	6	4.3		
	i3-12100TE	4	4		

* 14th Gen support PC Client use condition only.

1.5 System Configuration Recommendation

No.	CPU	Turbo Mode	MXM	PoE	Operating Temp.
1	35W	X (Disable)	NA	4-port total support maximum 50W, up to 25.5W each port	Up to 75°C
2	35W	X (Disable)	50W	4-port total support maximum 50W, up to 25.5W each port	Up to 55°C
3	35W	X (Disable)	80W	4-port total support maximum 30W, up to 25.5W each port	Up to 45°C
4	65W	X (Disable)	NA	4-port total support maximum 50W, up to 25.5W each port	Up to 55°C
5	65W	X (Disable)	50W	4-port total support maximum 50W, up to 25.5W each port	Up to 45°C
6	35W	O (Enable)	NA	4-port total support maximum 50W, up to 25.5W each port	Up to 75°C
7	35W	O (Enable)	50W	4-port total support maximum 30W, up to 25.5W each port	Up to 55°C
8	35W	O (Enable)	80W	4-port total support maximum 16W, up to 12.5W each port	Up to 45°C
9	65W	O (Enable)	NA	4-port total support maximum 22W, up to 12.5W each port	Up to 55°C
10	65W	O (Enable)	50W	4-port total support maximum 22W, up to 12.5W each port	Up to 45°C

*System total supports 200W

1.6 Mechanical Dimension

1.6.1 Dimensions of IVX-1000

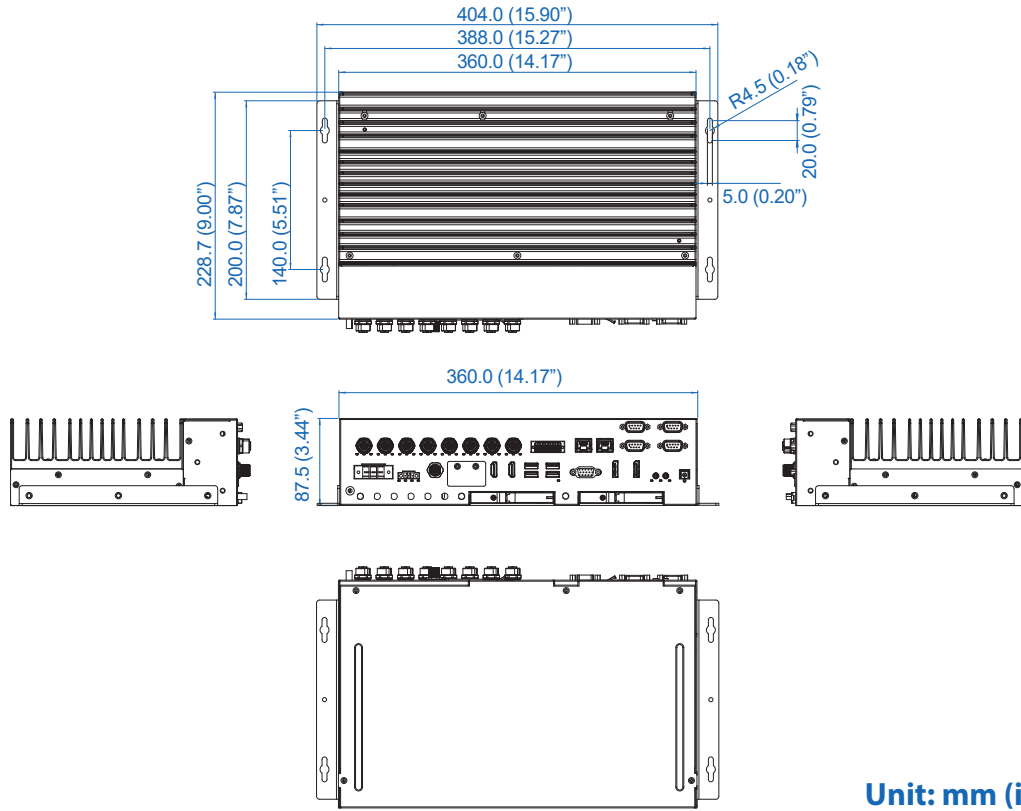

1.5.2 Dimensions of IVX-1000 ICY

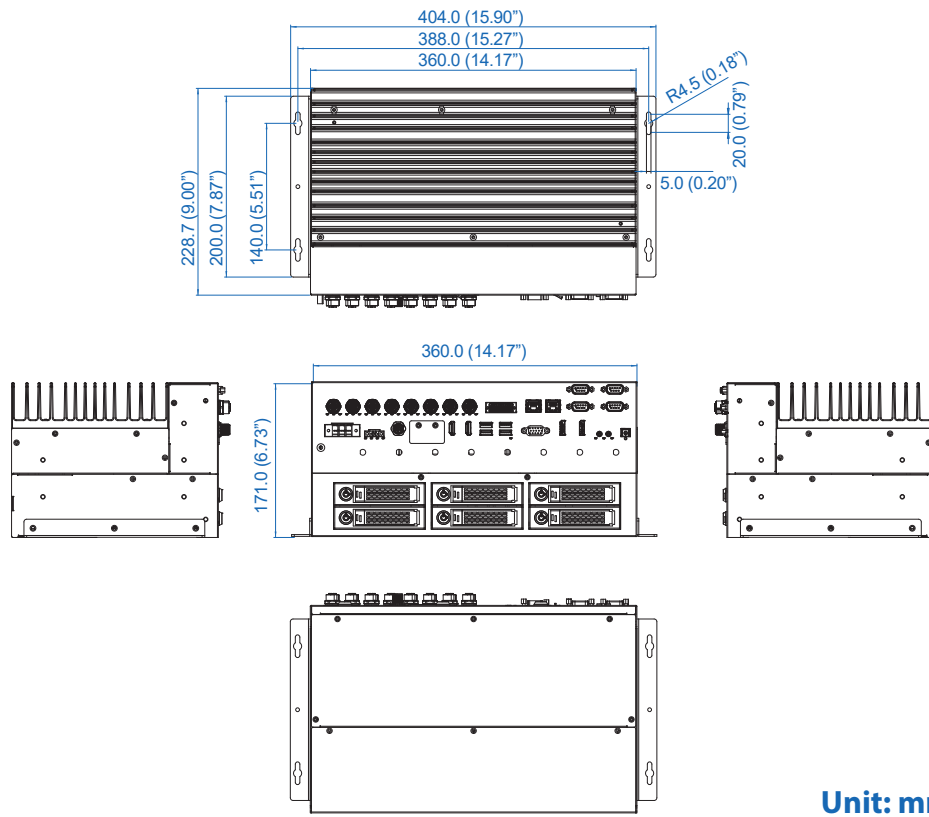











2

GETTING TO KNOW YOUR IVX-1000

2.1 Packing List of IVX-1000/IVX-1000 ICY











2.1.1 Packing List of IVX-1000

Item	Description	Qty
1	IVX-1000 High-Performance Fanless System (According to the configuration of you order, the IVX-1000 series may contain SSD/HDD and DDR5 SO-DIMM. Please verify these items if necessary.)	1
2	IVX-1000 series accessory box, which contains	1

Item	Description	Outlook	Usage	P/N	Qty
1	Tray's Key		SSD	N/A	2
2	Phillips F-Head M4×6L_Zi_B		Wall mount	53-M022450-300	6
3	Phillips P-Head M2.5×6L_Ni		Mini pcie	53-2426906-30B	1
4	Phillips P-Head M3×6L_Ni_Ny		M.2	53-2426206-80B	2
5	Phillips P-Head M3×4L_Ni_Ny		M.2	53-2426204-80B	8
6	Phillips P-Head M4×16L_Ni_Washer		WALL MOUNT	53-24D6416-30B	4
7	Terminal Block Plug_TJ0311520000G		Terminal Block	51-2211R03-S1A	1
8	Terminal Block Plug_0156-1A-6612-20		Terminal Block	51-2112R20-S1D	1
9	Terminal Block Plug_EC762VNM-03P		Terminal Block	51-2611R03-S1N	1
10	M.2_42 to 80 or 52 to 80		M.2	62-03P0997-30A	1

2.1.2 Packing List of IVX-1000-ICY

Item	Description	Qty
1	IVX-1000-ICY High-Performance Fanless System (According to the configuration of you order, the IVX-1000 ICY series may contain SSD/ HDD and DDR5 SO-DIMM. Please verify these items if necessary.)	1
2	IVX-1000-ICY series accessory box, which contains	1

Item	Description	Outlook	Usage	P/N	Qty
1	Tray's Key		ICY	N/A	6
2	Phillips F-Head M4×6L_Zi_B		Wall mount	53-M022450-300	6
3	Phillips P-Head M2.5×6L_Ni		Mini pcie	53-2426906-30B	1
4	Phillips P-Head M3×6L_Ni_Ny		M.2	53-2426206-80B	2
5	Phillips P-Head M3×4L_Ni_Ny		M.2	53-2426204-80B	8
6	Phillips P-Head M4×16L_Ni_Washer		WALL MOUNT	53-24D6416-30B	4
7	Terminal Block Plug_TJ0311520000G		Terminal Block	51-2211R03-S1A	1
8	Terminal Block Plug_0156-1A-6612-20		Terminal Block	51-2112R20-S1D	1
9	Terminal Block Plug_EC762VNM-03P		Terminal Block	51-2611R03-S1N	1
10	M.2_42 to 80 or 52 to 80		M.2	62-03P0997-30A	1

2.2 Front Panel I/O & Functions

In Vecow IVX-1000 series family, all I/O connectors are located on front panel. Most of the general connections to computer device, such as USB, LAN, Audio Jack, Display, HDMI, DP, VGA and any additional storage, are placed on the front panel.

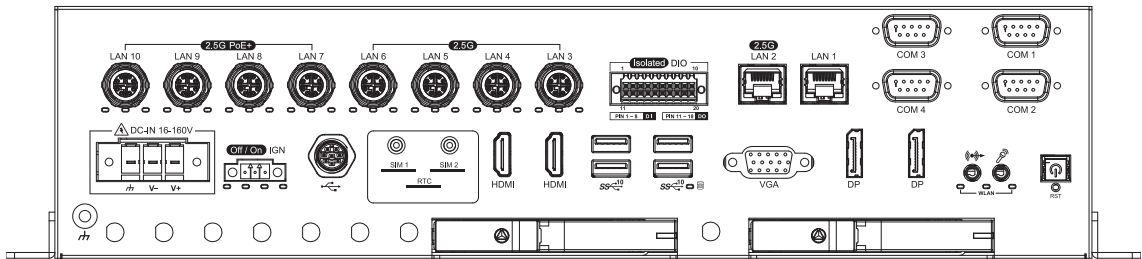

2.2.1 POWER TERMINAL BLOCK

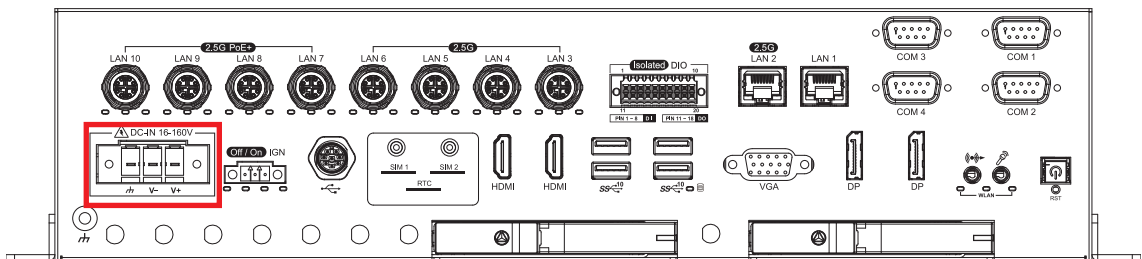

This system supports 16V to 160V DC power input by terminal block in the rear side. And the pin define is as below table.

PIN NO.	Definition
1	V+
2	V-
3	Chassis Ground



2.2.2 Power Button and Power LED

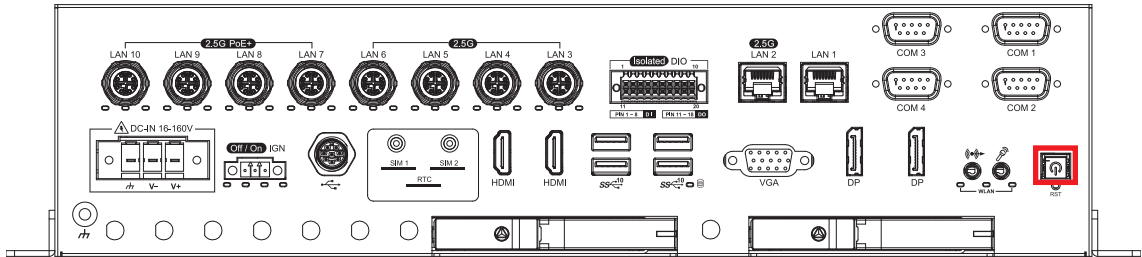

The Power Button is a non-latched switch with dual color LED indication. It indicates power status: S0, S3 and S5. More detail LED indications are listed as follows:

LED Color	Power Status	System Status
Solid Blue	S0	System working
Solid Orange	S3, S5	Suspend to RAM, System off with standby power

To power on the system, press the power button and then the blue LED is lightened. To power off the system, you can either command shutdown by OS operation, or just simply press the power button.

If system error, you can just press the power button for 4 seconds to shut down the machine directly. Please do note that a 4-second interval between each 2 power-on/ power-off operation is necessary in normal working status. (For example, once turning off the system, you have to wait for 4 seconds to initiate another power-on operation.)

2.2.3 Reset Tact Switch

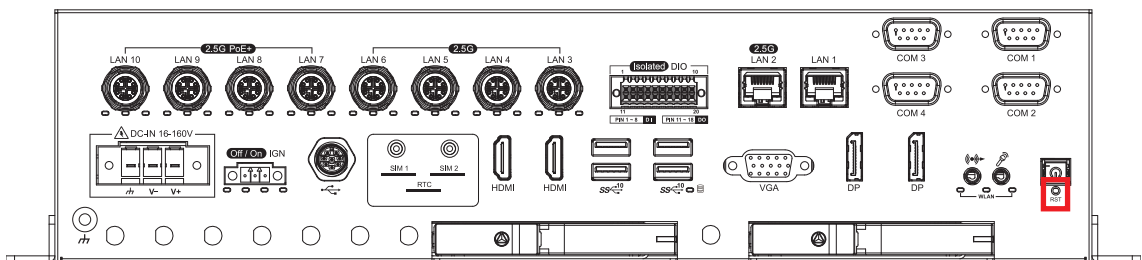

It is a hardware reset switch. Use this switch to reset the system without power off the system. Press the Reset Switch for a few seconds, and then reset will be enabled.

2.2.4 SIM1/SIM2

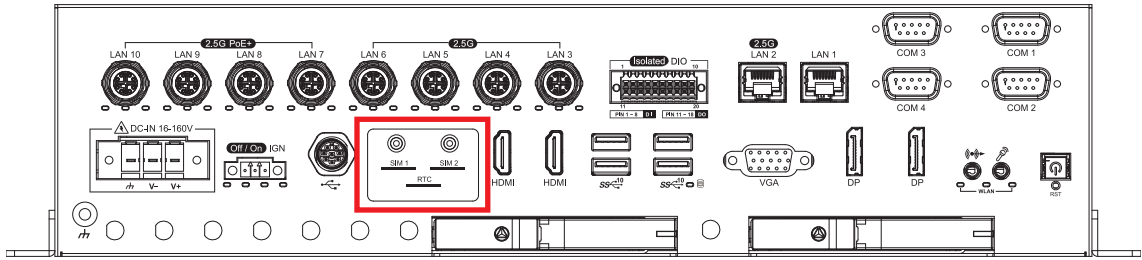

SIM1/SIM2 mapping table as below table

SIM SLOT	SOURCE CONNECTOR
SIM1	M2B_CN1
SIM2	MPCIE1

Note: The Nano SIM card sockets do not support hot-plug. Please make sure to unplug the system power before inserting the Nano SIM card(s).

2.2.5 HDD LED Indicator

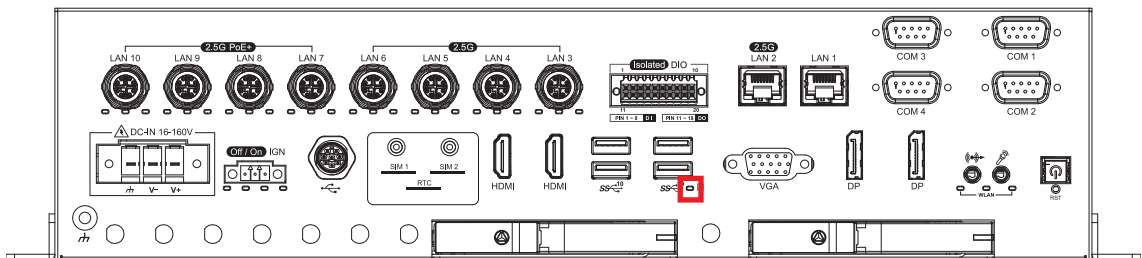

HDD LED/ Yellow: A Hard Disk. If the LED is on, it indicates that the system's storage is functional. If it is off, it indicates that the system's storage is not functional. If it is flashing, it indicates data access activities.

LED Color	Power Status	System Status
Yellow	HDD	<ul style="list-style-type: none"> On/Off: Storage status, function or not Twinkling: Data transferring

2.2.6 HDMI Connector

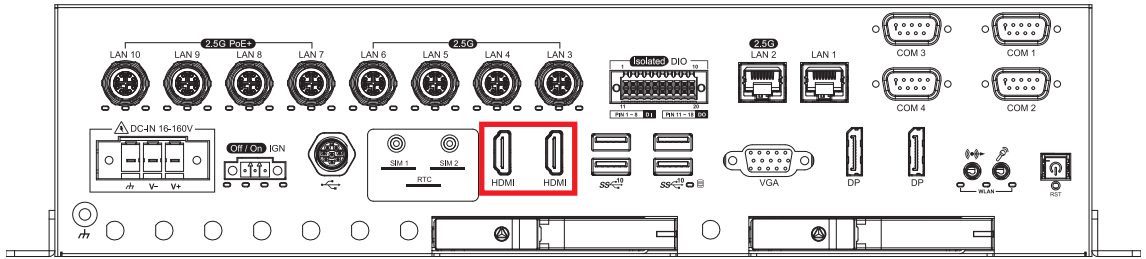

Onboard HDMI Port supports DDC channel mode. The connection supports up to 4Kx2K 48-60 Hz 24 bpp(RGB/YUV444),4Kx2K 48-60 Hz 12 bpc(YUV420)

2.2.7 VGA Connector

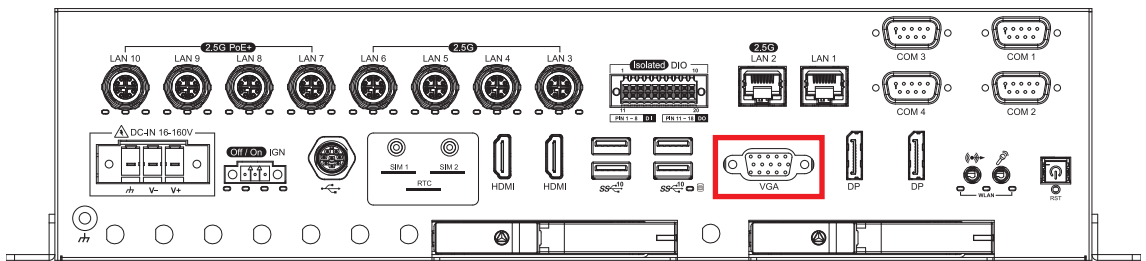

The pin assignments of the VGA connector are shown below

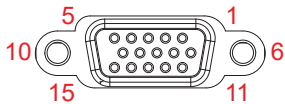

PIN NO.	DESCRIPTION
1	Red Color Signal
2	Green Color Signal
3	Blue Color Signal
4	NC
5	Ground
6	Ground
7	Ground
8	Ground
9	VCC
10	Ground
11	NC
12	DDC-DATA
13	H-Sync.
14	V-Sync.
15	DDC-CLK

2.2.8 Display Port

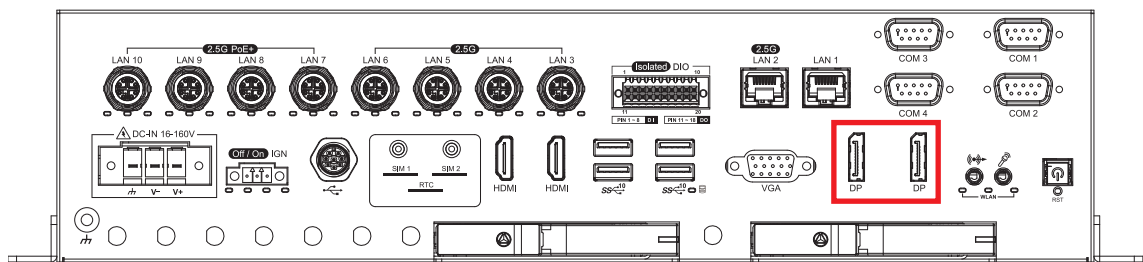

Onboard Display Port supports auxiliary channel dual mode ,and the connection Support up to 4096x2304 resolution at 60 Hz

Multi-Stream Transport Display Resolutions Table:

Multi-Stream Transport Display	Max. Resolution
Two panel Displays concurrently	4096x2304 @60Hz

2.2.9 USB 3.2

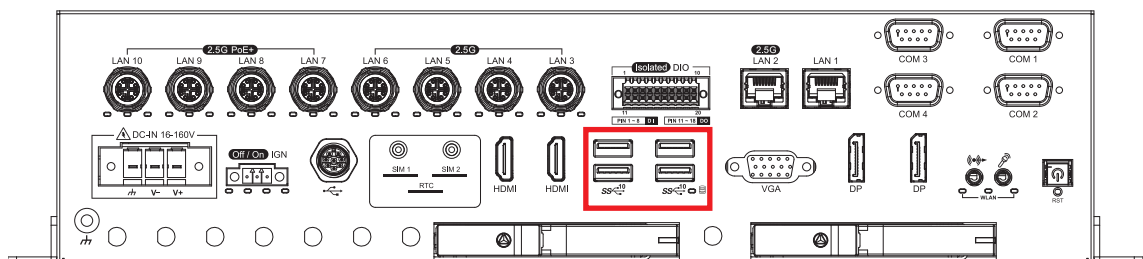

There are 4 USB 3.2 connections available supporting up to 10Gb per second data rate in the front side of IVX-1000. It is also compliant with the requirements of Speed (SS), High Speed (HS), Full Speed (FS) and Low Speed (LS).

2.2.10 Ethernet Port

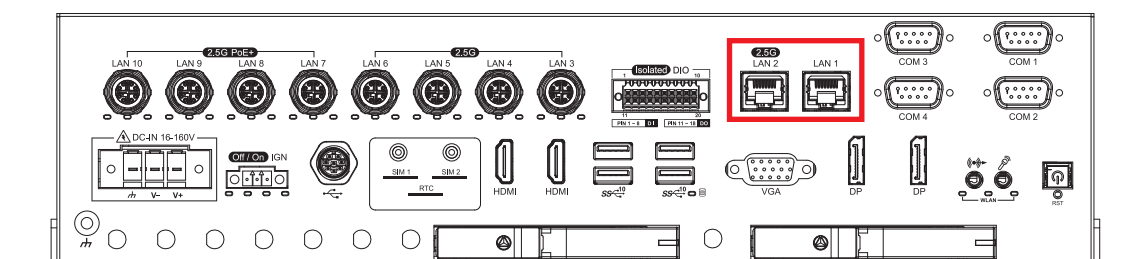

There are two 8-pin RJ-45 jacks supporting 10/100/1000/2500 Mbps Ethernet connections on the front side of IVX-1000. LAN 1 is powered by Intel® I219LM Ethernet engine, and LAN 2 is powered by Intel I226 Ethernet engine. When LAN 1 works in normal status, iAMT 11.0 function is enabled.

Connetor	LAN Chip	Function
LAN1	Intel I219	RJ45(10/100/1000Mbps)
LAN2	Intel I226	RJ45(10/100/1000/2500Mbps)

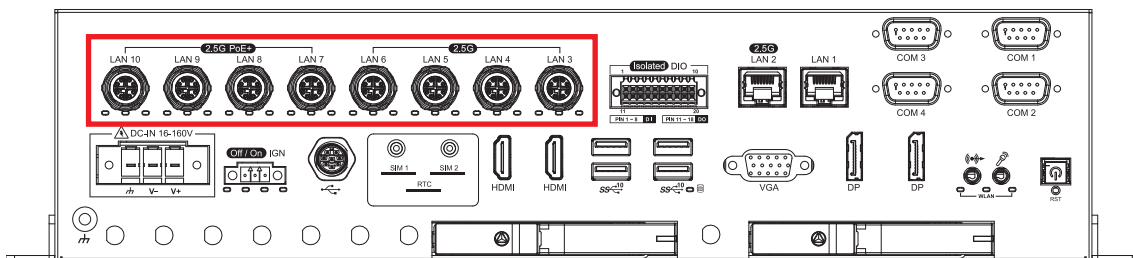

There are 8 M12 jacks supporting 10/100/1000/2500 Mbps Ethernet connections on the front side of IVX-1000.

LAN 3~LAN10 is powered by Intel I226 Ethernet engine

Connetor	LAN Chip	Function
LAN3	Intel I226	M12 X Code (10/100/1000/2500Mbps)
LAN4		
LAN5		
LAN6		
LAN7 w/POE+		
LAN8 w/POE+		
LAN9 w/POE+		
LAN10 w/POE+		

Using suitable RJ-45 cable, you can connect the system to a computer or to any other devices with Ethernet connection; for example, a hub or a switch. Moreover, both LAN 1 and LAN 2 support Wake on LAN and Pre-boot functions. The pin-outs of LAN 1 and LAN 2 are listed as follows:

PIN NO.	10/ 100 Mbps	1000/2500 Mbps
1	E_TX+	MDIO_P
2	E_TX-	MDIO_N
3	E_RX+	MDI1_P
4	----	MDI2_P
5	----	MDI2_N
6	E_RX-	MDI1_N
7	-----	MDI3_P
8	-----	MDI3_N

Using suitable M12 LAN cable, you can connect the system to a computer, or to any other devices with Ethernet connection, for example, a hub or a switch. Moreover, LAN 3 to LAN 10 supports Wake on LAN and Pre-boot functions. The pin-outs of LAN 3 to LAN10 are listed as follows:

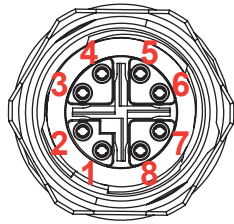

PIN NO.	1000/2500 Mbps
1	MDI0_P
2	MDI0_N
3	MDI1_P
4	MDI1_N
5	MDI3_P
6	MDI3_N
7	MDI2_N
8	MDI2_P

Each LAN port is supported by standard RJ-45 connector with LED indicators to present Active/Link/Speed status of the connection.

The LED indicator on the right bottom corner lightens in solid green when the cable is properly connected to a 100 Mbps Ethernet network; The LED indicator on the right bottom corner lightens in solid orange when the cable is properly connected to a 1000Mbps Ethernet network; The left LED will keep twinkling/off when Ethernet data packets are being transmitted/received.

LAN	LED Location	LED Color	10 Mbps	100 Mbps	1000 Mbps	2500 Mbps
LAN1	Left	Green/Orange	Off	Solid Orange	Solid Green	x
	Right	Yellow	Twinkling Yellow	Twinkling Yellow	Twinkling Yellow	x
LAN2	Left	Green/Orange	Off	Off	Solid Green	Solid Orange
	Right	Yellow	Twinkling Yellow	Twinkling Yellow	Twinkling Yellow	Twinkling Yellow

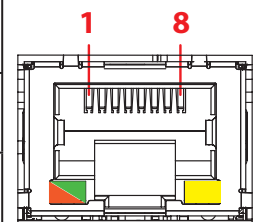

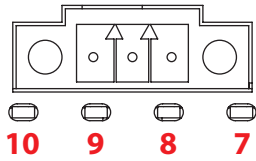
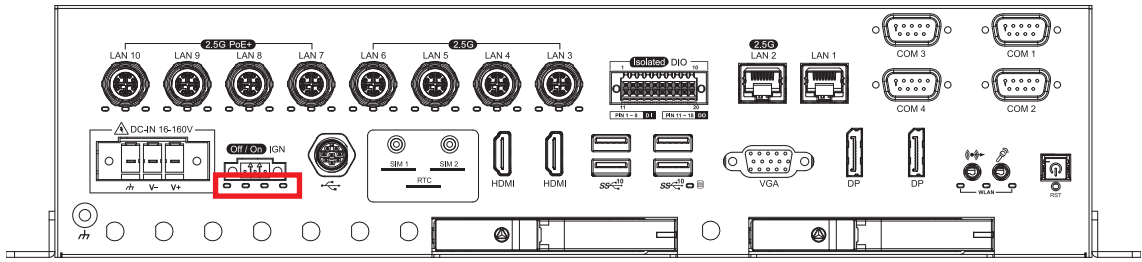

PoE LED	LED Color	PoE Status
POE_LED1(LAN7)	Solid Green	PoE ON
POE_LED2(LAN8)		
POE_LED3(LAN9)		
POE_LED4(LAN10)		

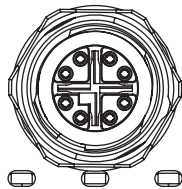
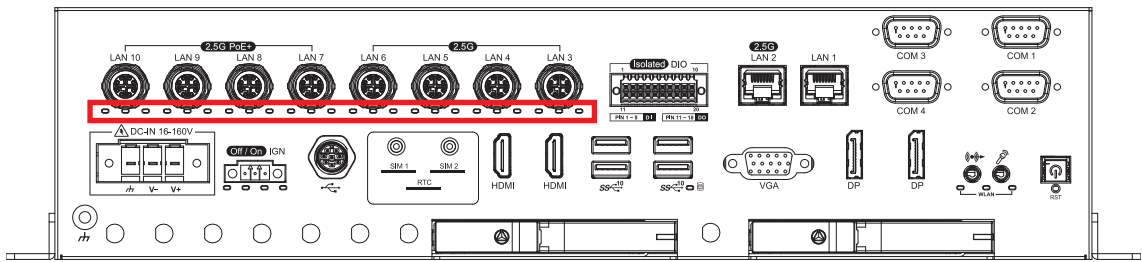

LED Location	status	LED Color
Left	Active	Twinkling green
Middle	2500Mbps	Solid green
Right	1000Mbps	Solid green

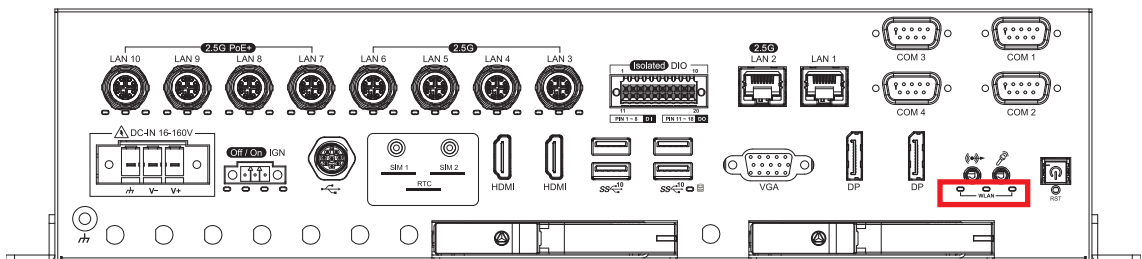

Mini PCIe Slot/M.2 KEY B/M.2 KEY E WLAN LED Mapping Table :

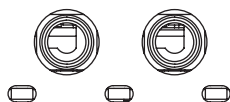

LED Location	WLAN LED
Right	M.2 KEY B
middle	Mini PCIe
Left	M.2 KEY E

2.2.12 Audio Jack

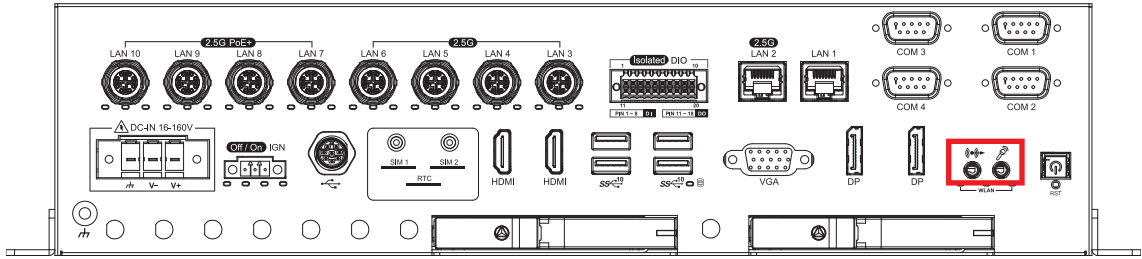

There are 2 audio connectors, Mic-in and Line-out, in the front side of IVX-1000. Onboard Realtek ALC888 audio codec supports 7.1 channel HD audio and fully complies with Intel® High Definition Audio (Azalia) specifications.

To utilize the audio function in Windows platform, you need to install corresponding drivers for both Intel Sunrise Point chipset and Realtek ALC888 codec.

2.2.13 USB2.0

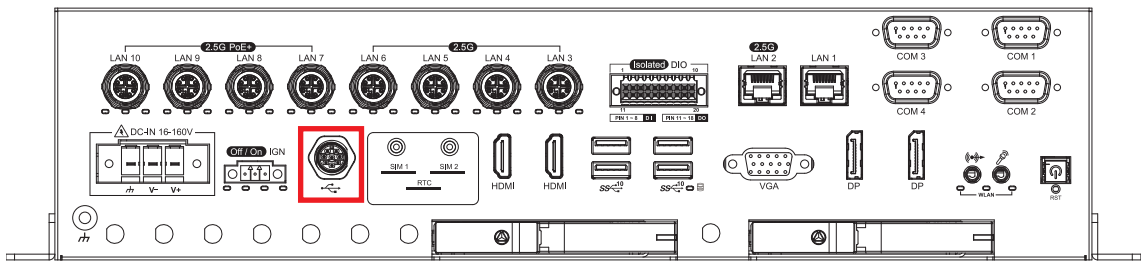

There are 2 USB 2.0 connections available supporting up to 480MB per second data rate. The pin-outs of USB2.0 are listed as follows:

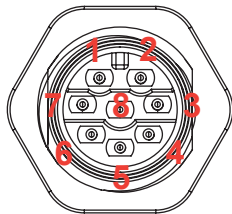

Pin No.	USB2.0
1	USB_1D-
2	USB_1D+
3	USB_VCC
4	USB_GND
5	USB_2D-
6	USB_2D+
7	USB_VCC
8	USB_GND

2.2.14 SSD/ HDD Tray

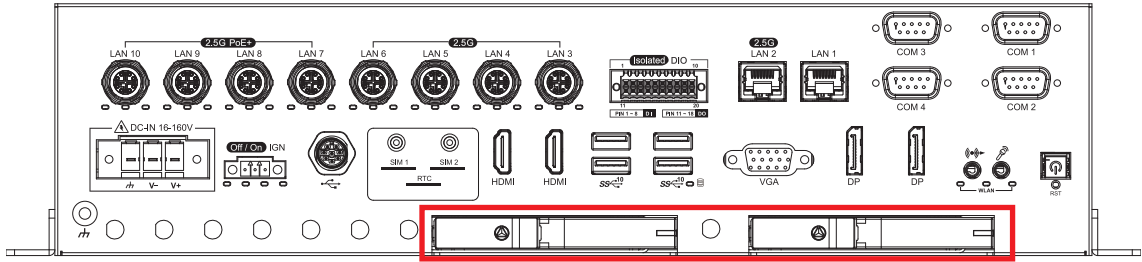

There are 2 front-access 2.5” SSD/ HDD trays in the front side of IVX-1000 and 6 2.5” SSD/ HDD ICY dock trays in the front side of IVX-1000-ICY.

Just trigger to open the SSD/ HDD tray, up to 4TB is available.

2.2.15 Isolated DIO

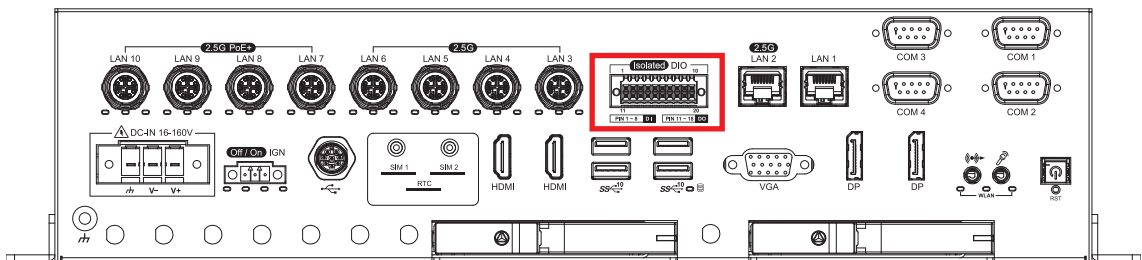

There is a 16-bit (8-bit DI, 8-bit DO) connectors in the rear side. DI/DIO support NPN(sink) and PNP(Source) mode, Each DI channel is equipped with a photocoupler for isolated protection. Each DO with isolator chip, Config by a Jumper for each DIO connector.

DO Safety-Related Certifications:

- 4242-VPK Basic Isolation per DIN V VDE V 0884-10 and DIN EN 61010-1
- 3-KVRMS Isolation for 1 minute per UL 1577
- CSA Component Acceptance Notice 5A, IEC 60950-1 and IEC 61010-1 End Equipment Standards
- GB4943.1-2011 CQC Certified

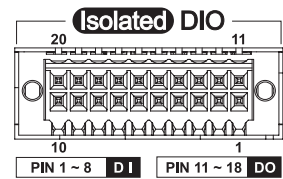

PIN NO.	Definition	Mapping to SIO GPIO Function
1	INPUT 0	SIO_GPI80
2	INPUT 1	SIO_GPI81
3	INPUT 2	SIO_GPI82
4	INPUT 3	SIO_GPI83
5	INPUT 4	SIO_GPI84
6	INPUT 5	SIO_GPI85

7	INPUT 6	SIO_GPI86
8	INPUT 7	SIO_GPI87
9	DI_COM	
10	DIO_GND	
11	OUTPUT 0	SIO_GPO70
12	OUTPUT 1	SIO_GPO71
13	OUTPUT 2	SIO_GPO72
14	OUTPUT 3	SIO_GPO73
15	OUTPUT 4	SIO_GPO74
16	OUTPUT 5	SIO_GPO75
17	OUTPUT 6	SIO_GPO76
18	OUTPUT 7	SIO_GPO77
19	DIO_GND	
20	External 6-40VDC (NPN) External 6-48VDC(PNP)	

DI Reference Circuit :

Sink Mode (NPN)

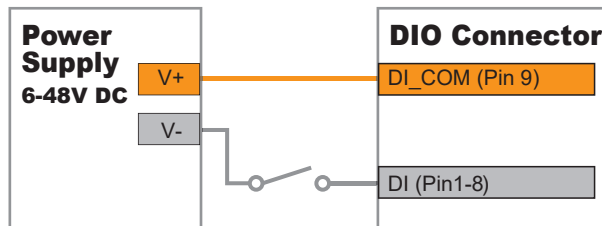

Source Mode (PNP)

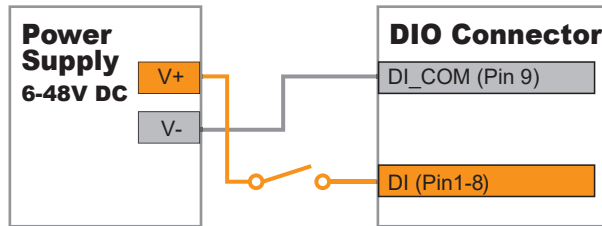

DO Reference Circuit :

Sink Mode
(NPN, Default)

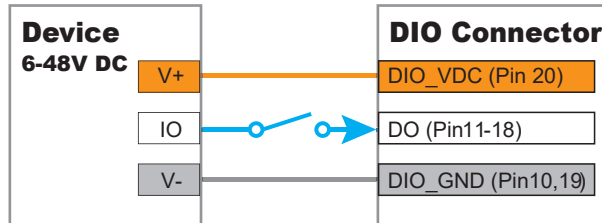

Source Mode
(PNP)

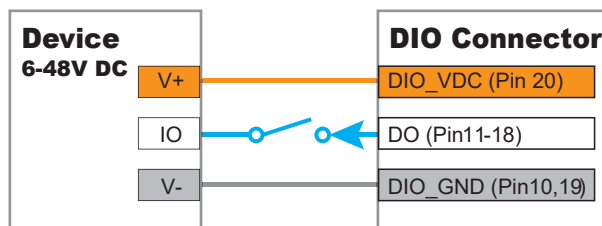

2.2.16 Isolation COM ports

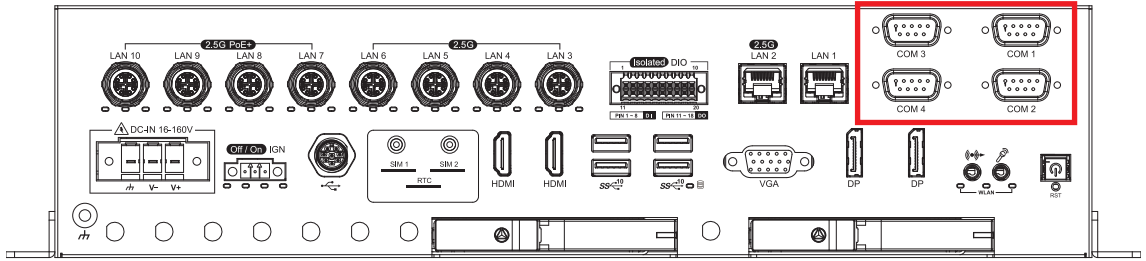

Serial port 1 to 4 (COM 1 to 4) can be configured for RS-232, RS-422, or RS-485 with auto flow control communication. The default definition of COM 1 to COM4 is RS-232, if you want to change to RS-422 or RS-485, you can find the setting in BIOS.

BIOS Setting	Function
COM 1 COM 2 COM 3 COM 4	RS-232
	RS-422 (5-wire)
	RS-485
	RS-485 w/z auto-flow control

Serial Port	Pin No.	RS-232	RS-422 (5-wire)	RS-485 (3-wire)
1 to 4	1	DCD	TXD-	DATA-
	2	RXD	TXD+	DATA+
	3	TXD	RXD+	-----
	4	DTR	RXD-	-----
	5	GND	GND	GND
	6	DSR	-----	-----
	7	RTS	-----	-----
	8	CTS	-----	-----
	9	RI	-----	-----

2.2.17 Remote Power On/Off Switch & IGN ITION Terminal Block

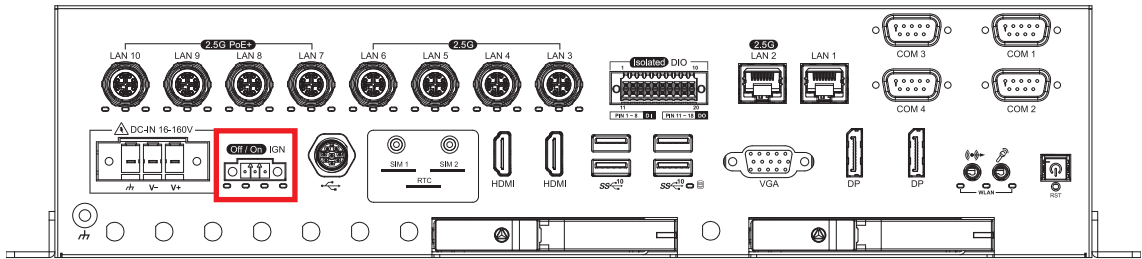

It is a 2-pin power-on or power-off switch through Phoenix Contact terminal block. You could turn on or off the system power by using this contact. This terminal block supports dual function of soft power-on/ power-off (instant off or delay 4 second), and suspend mode.

PIN NO.	Definition
1	Ignition
2	SW+
3	SW-

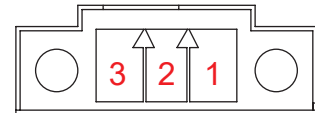

2.3 Main Board Expansion Connectors

2.3.1 Top View of IVX-1000 Main Board with Connector Location

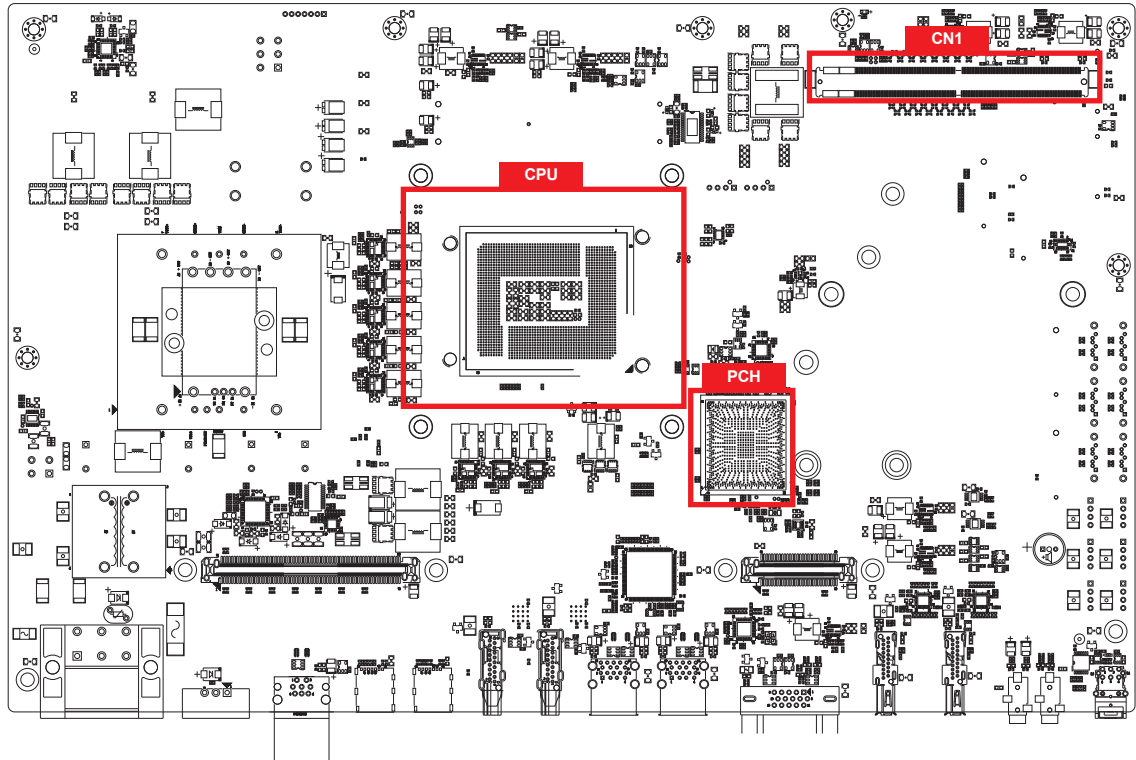

2.3.2 BOTTOM View of IVX-1000 Main Board with Connector Location

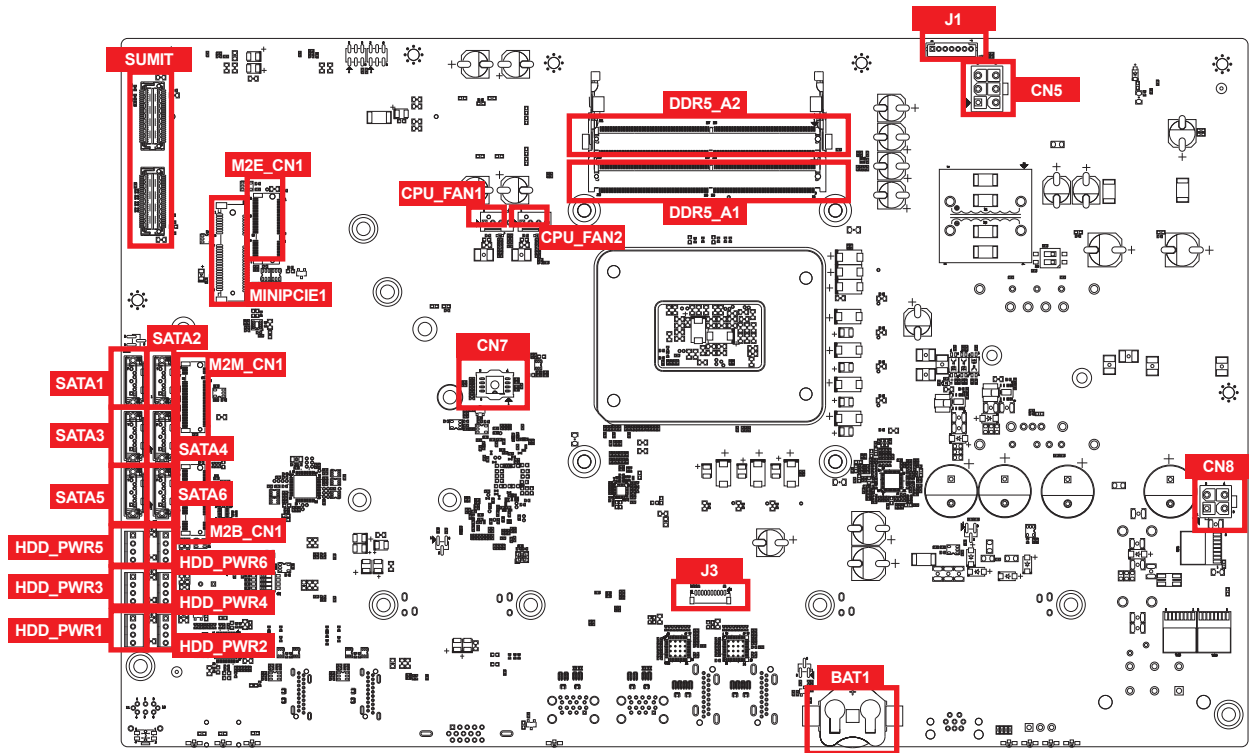

2.3.3 MXM Connector(CN1)

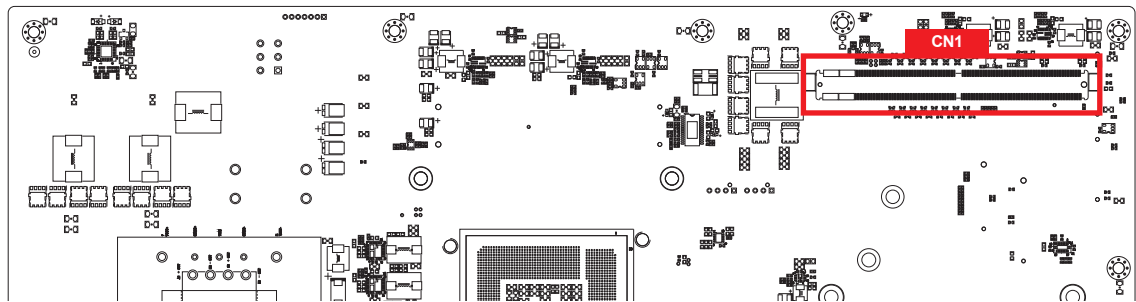

2.3.4 Detect battery capacity (J1)

Detect battery capacity for superCAP module

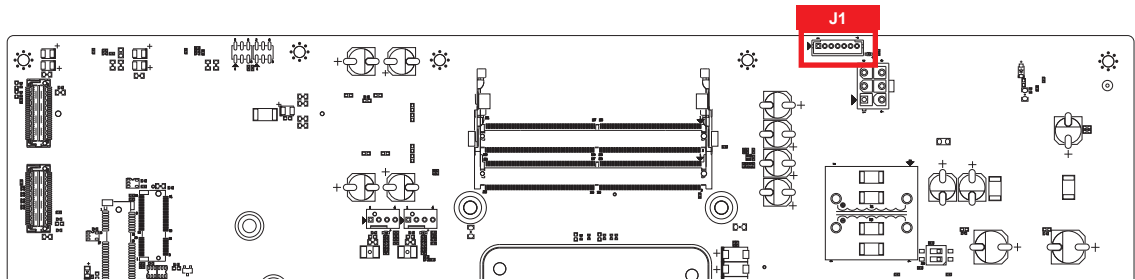

PIN NO.	Definition	Layout
PIN1	GND	
PIN2	SMB_DATA	
PIN3	SMB_CLK	
PIN4	PFO#	
PIN5	PFI	
PIN6	NC	
PIN7	NC	

2.3.5 DDR5 Slot

There are 2 DDR5 slot, support DDR5 4800 ECC SODIMM, max 64GB and each channel 32GB

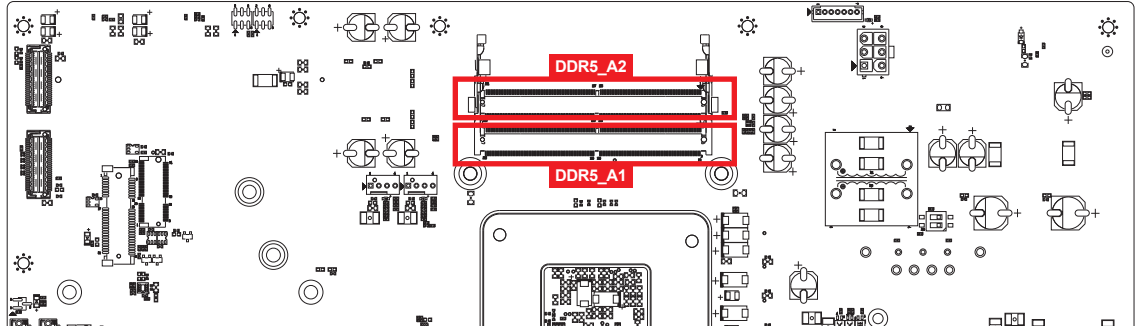

Slot	Description
DDR5_A1	DDR5 Channel A
DDR5_A2	DDR5 Channel B

2.3.6 BIOS Socket(CN7)

If the BIOS need to be changed, please contact the Vecow RMA service team.

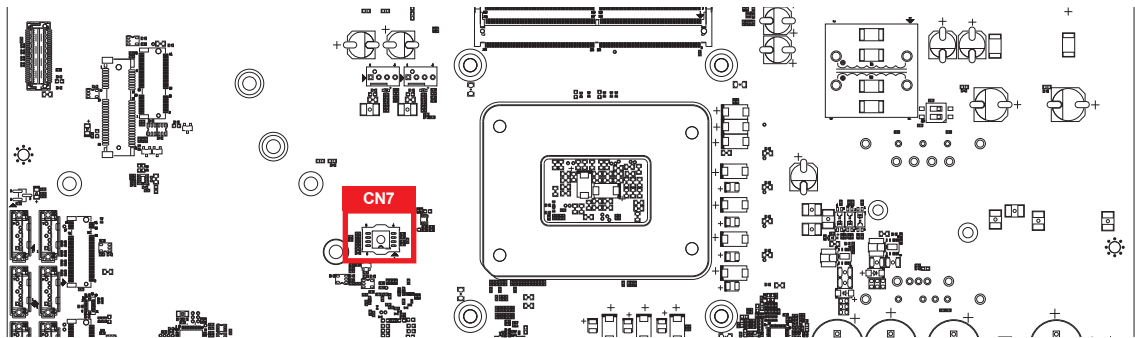

2.3.7 SATA Connector(SATA1~SATA6)

Standard 7 PIN SATA Connector

There are 2 onboard high performance Serial ATA III (SATA III) on IVX-1000. It supports higher storage capacity with less cabling effort and smaller required space. The pin assignments of SATA1 to SATA6 are listed in the following table :

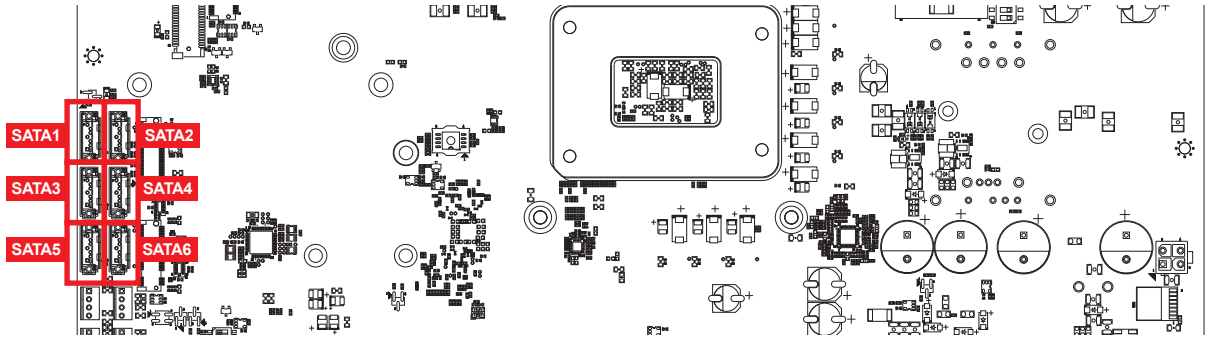

PIN NO.	Definition	Layout
1	GND	
2	TXP	
3	TXN	
4	GND	
5	RXN	
6	RXP	
7	GND	

2.3.8 SATA Power Header(HDD_PWR1~HDD_PWR6)

Standard, all form factor 1x4p power header

There are 6 HDD power header on board and each power header supports SIX 2.5" SATA HDD.

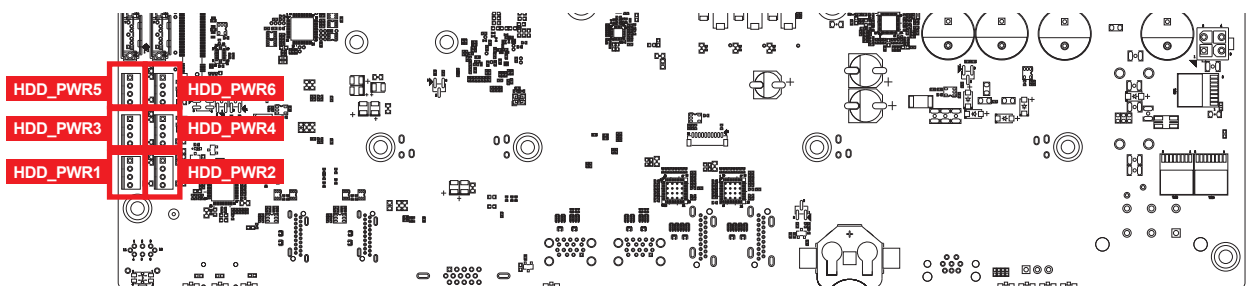

PIN NO.	Definition	Layout
1	+12V	
2	GND	
3	GND	
4	+5V	

2.3.9 ESPI Port 80 Header (J3)

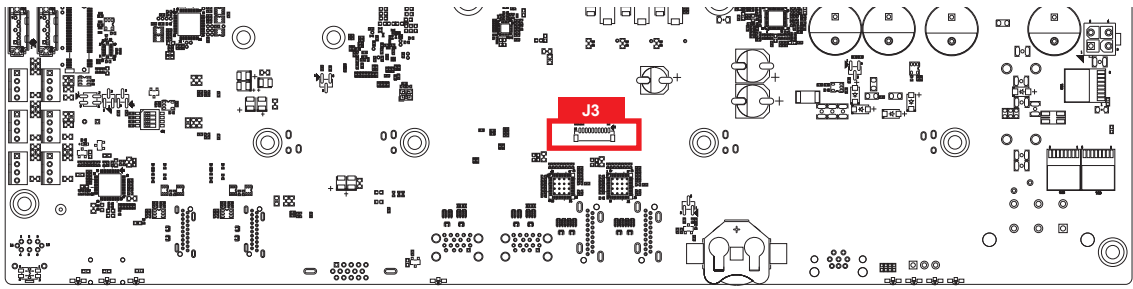

The pin assignments of J3 are listed in the following table.

PIN NO.	Function	Layout
1	+V3.3S	<p>The diagram shows a vertical header connector with 10 pins. Pin 1 is at the top, and pin 10 is at the bottom. The pins are numbered 1 through 10 from top to bottom.</p>
2	Port 80_ESPI_CS#	
3	Port 80_ESPI_IO0	
4	Port 80_ESPI_IO1	
5	Port 80_ESPI_IO2	
6	Port 80_ESPI_IO3	
7	GND	
8	Port 80_ESPI_CLK	
9	RST 80_ESPI_RST#	
10	GND	

2.3.10 SUMIT Connector(SUMITA, SUMITB)

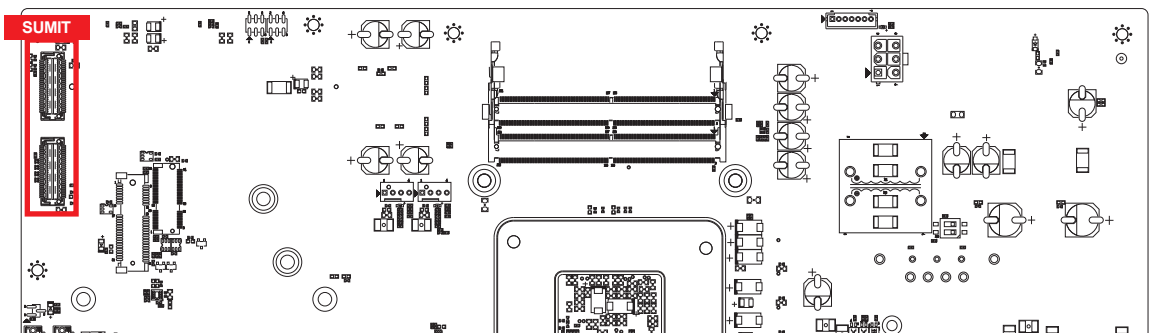

2.3.11 MINI PCIE Connector(MPCIE1)

Standard full length Mini PCIe slot:

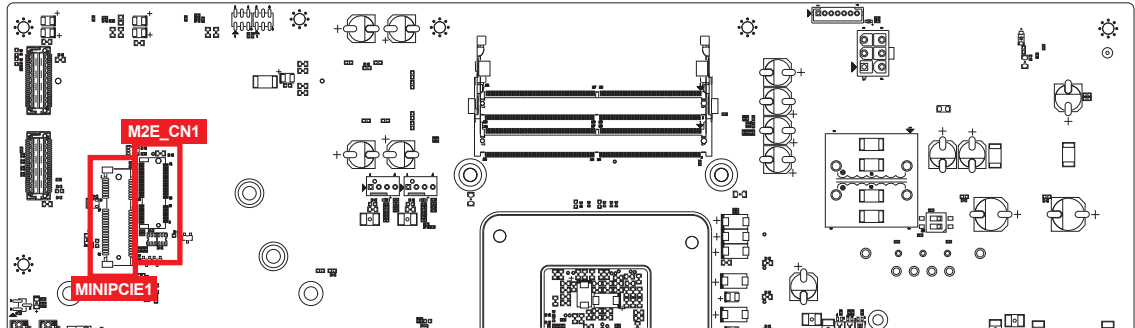

Pin Out :

Pin No.	Description	Pin No.	Description
51	Reserved	52	+3.3Vaux
49	Reserved	50	GND
47	Reserved	48	+1.5V
45	Reserved	46	Reserved
43	GND	44	Reserved
41	+3.3Vaux	42	Reserved
39	+3.3Vaux	40	GND
37	GND	38	USB_D+
35	GND	36	USB_D-
33	PETp0	34	GND
31	PETn0	32	SMB_DATA
29	GND	30	SMB_CLK
27	GND	28	+1.5V
25	PERn0	26	GND
23	PERp0	24	+3.3Vaux
21	GND	22	PERST#
19	Reserved	20	reserved
17	Reserved	18	GND
Mechanical Key			
15	GND	16	UIM_VPP
13	REFCLK+	14	UIM_RESET

Pin No.	Description	Pin No.	Description
11	REFCLK-	12	UIM_CLK
9	GND	10	UIM_DATA
7	CLKREQ#	8	UIM_PWR
5	Reserved	6	1.5V
3	Reserved	4	GND
1	WAKE#	2	3.3Vaux

2.3.12 RTC Battery(BAT1)

The system's real-time clock is powered by a lithium battery. It is Equipped with Panasonic BR2032 190mAh lithium battery. It is recommended that you not replace the lithium battery on your own. If the battery needs to be changed, please contact the Vecow RMA service team.

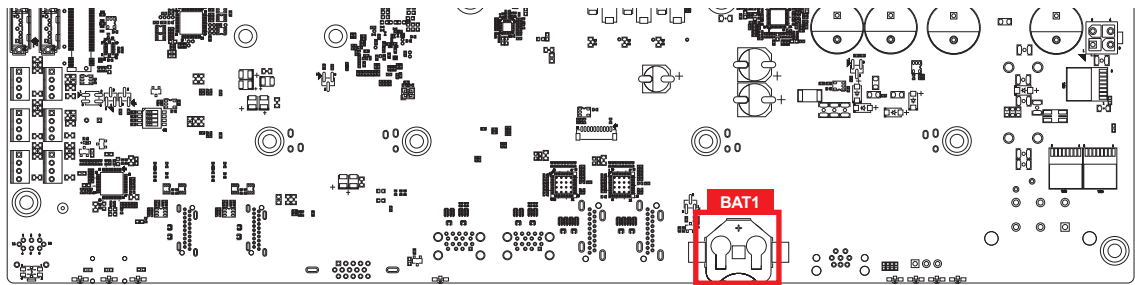

2.3.13 FAN CONNECTOR(CPU_FAN1 /SYS_FAN1)

Fan power connector supports for additional thermal requirements. The pin assignments of CPU_FAN1 and SYS_FAN1 are listed in the following table.

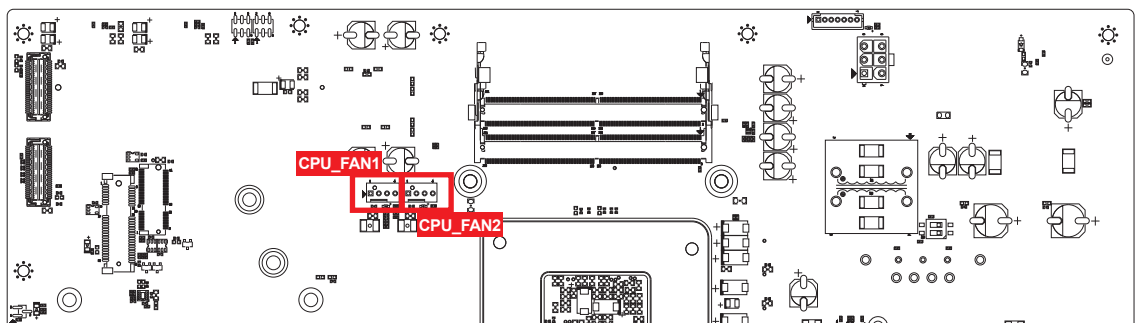

Location	Pin	Definition	Layout
CPU_FAN1 SYS_FAN2	1	GND	
	2	+12V (2A max)	
	3	Fan speed sensor	
	4	Fan PWM	

2.3.14 M.2 KEY-E (M2E_CN1)

M.2 KEY E: USB2.0/PCIex1 M.2 key E connector is suitable for applications that use wireless connectivity including Wi-Fi, Bluetooth, NFC or GNSS. Module card types include 2230

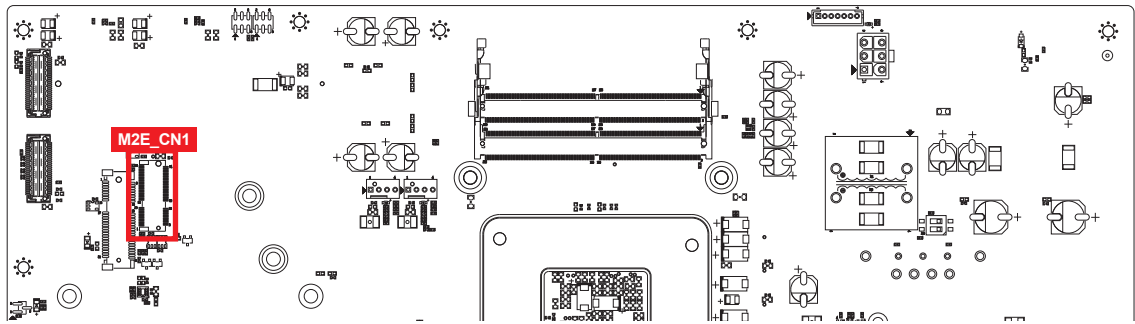

Pin Definition:

Pin No.	Description	Pin No.	Description
75	GND	74	+V3.3_AUX
73	NC	72	+V3.3_AUX
71	NC	70	NC
69	GND	68	PCIE_CLK_REQ#
67	NC	66	NC
65	NC	64	M2E_REFCLK
63	GND	62	SMB_ALERT#
61	NC	60	SMB_CLK
59	NC	58	SMB_DATA
57	GND	56	M2E_WLAN_DISABLE
55	PCIE_WAKE#	54	M2E_BT_DISABLE
53	PCIE_CLK_REQ0#	52	PLTRST#
51	GND	50	SUS_CLK
49	PCIE_100M_CLK__N	48	NC

Pin No.	Description	Pin No.	Description
47	PCIE_100M_CLK__P	46	NC
45	GND	44	CNVI_BLANKING
43	PCIE_RX_N	42	CL_CLK
41	PCIE_RX_P	40	CL_DATA
39	GND	38	CL_RST_N
37	PCIE_TX_N	36	NC
35	PCIE_TX_P	34	NC
33	GND	32	NC
Mechanical Key			
23	NC		
21	NC	22	NC
19	GND	20	NC
17	NC	18	GND
15	NC	16	LED2#
13	GND	14	NC
11	NC	12	NC
9	NC	10	NC
7	GND	8	NC
5	USB-	6	LED1#
3	USB+	4	+V3.3_AUX
1	GND	2	+V3.3_AUX

2.3.15 M.2 KEY-M(M2M_CN1)

M.2 key M connector is suitable for applications that use Host I/Fs supported by either PCIe Module card types include 2280 (Only Support PCIE)

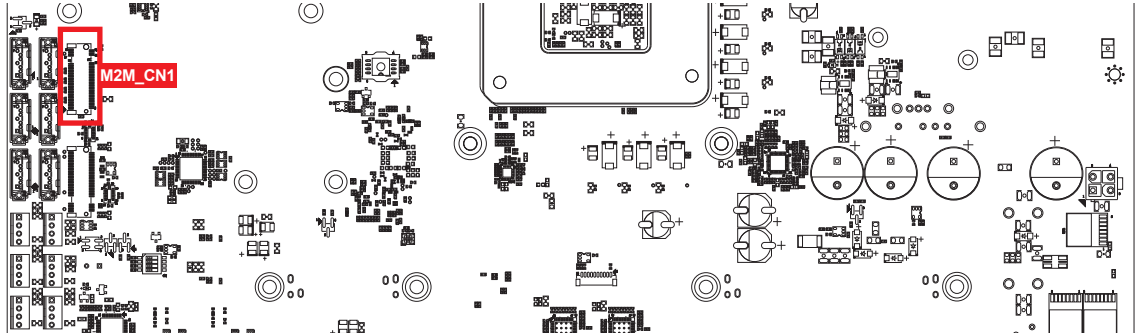

Pin Definition:

Pin No.	Description	Pin No.	Description
75	Ground		
73	Ground	74	3.3V
71	Ground	72	3.3V
69	PEDET	70	3.3V
67	Ground	68	NC
Mechanical Key			
23	NC		
21	NC	22	NC
19	GND	20	NC
17	NC	18	GND
15	NC	16	LED2#
13	GND	14	NC
11	NC	12	NC
9	NC	10	NC
7	GND	8	NC
5	USB-	6	LED1#
3	USB+	4	+V3.3_AUX
1	GND	2	+V3.3_AUX
57	Ground	58	NC
55	REFCLKp	56	NC
53	REFCLKn	54	PEWAKE#

Pin No.	Description	Pin No.	Description
51	Ground	52	CLKREQ#
49	PETp0/SATA_A+	50	PERST#
47	PETn0/SATA_A-	48	NC
45	Ground	46	NC
43	PERp0/SATA_B-	44	NC
41	PERn0/SATA_B+	42	NC
39	Ground	40	NC
37	PETp1	38	DEVSLP
35	PETn1	36	NC
33	Ground	34	NC
31	PERp1	32	NC
29	PERn1	30	NC
27	Ground	28	NC
25	PETp2	26	NC
23	PETn2	24	NC
21	Ground	22	NC
19	PERp2	20	NC
17	PERn2	18	3.3V
15	Ground	16	3.3V
13	PETp3	14	3.3V
11	PETn3	12	3.3V
9	Ground	10	LED1#
7	PERp3	8	NC
5	PERn3	6	NC
3	Ground	4	3.3V
1	Ground	2	3.3V

2.3.16 M.2 KEY-B(M2B_CN1)

M.2 KEY-B support USB3.0/USB2.0 and PCIe x1, if you want to change to USB3.0 or PCIe x1, you can find the setting in BIOS.

Module card types include 3042,3052.

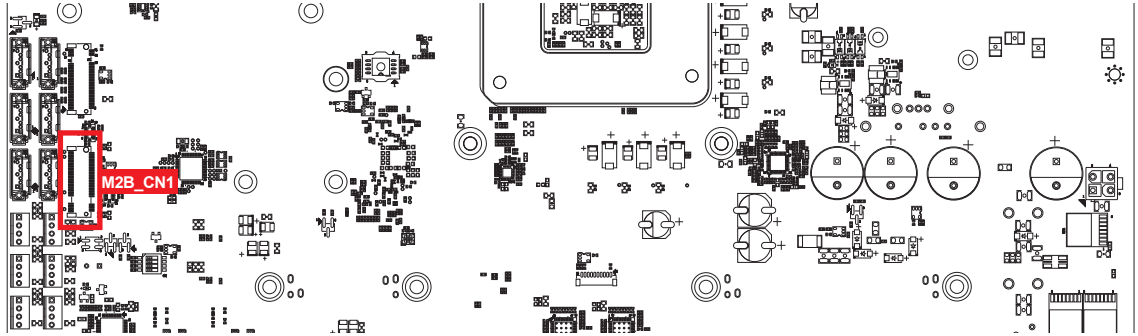

Pin Definition:

Pin No.	Description	Pin No.	Description
		80	Ground
75	NC		
73	Ground	74	3.3V
71	Ground	72	3.3V
69	CONFIG_1	70	3.3V
67	NC	68	NC
65	NC	66	SIM DETECT
63	NC	64	NC
61	NC	62	NC
59	NC	60	NC
57	Ground	58	NC
55	REFCLKp	56	NC
53	REFCLKn	54	PEWAKE#
51	Ground	52	CLKREQ#
49	PETn0/SATA-A+	50	PERST#
47	PETn0/SATA-A-	48	NC
45	Ground	46	NC
43	PERn0/SATA-B-	44	NC
41	PERn0/SATA-B+	42	NC
39	Ground	40	NC

Pin No.	Description	Pin No.	Description
37	NC	38	DEVSLP
35	NC	36	UIM-PWR
33	Ground	34	UIM-DATA
31	NC	32	UIM-CLK
29	NC	30	UIM-RESET
27	Ground	28	NC
25	NC	26	NC
23	NC	24	NC
21	NC	22	NC
		20	NC
Mechanical Key			
11	Ground		
9	USB-	10	LED_1#
7	USB+	8	W_DISABLE1
5	Ground	6	FULL_CARD_PWR_OFF/ON
3	Ground	4	3.3V
1	NC	2	3.3V

2.3.17 superCAP connector(CN5)

CN5 for Connect superCAP module

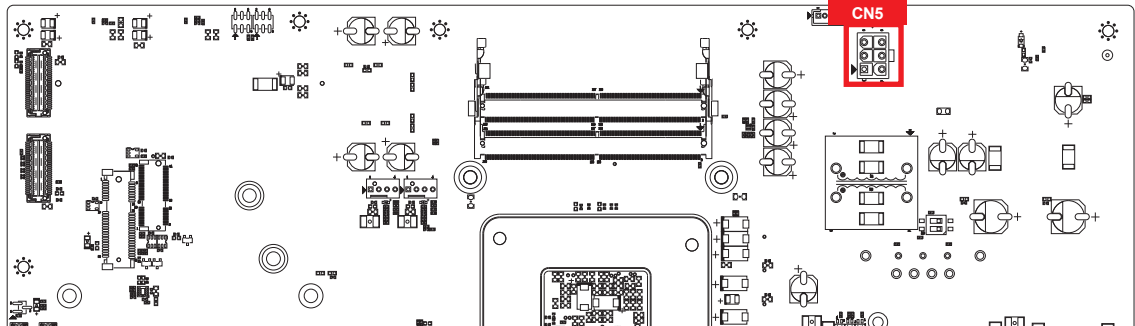

PIN NO.	Definition	Layout
PIN1	+V15	
PIN2	+V15	
PIN3	+V15	
PIN4	GND	
PIN5	GND	
PIN6	GND	

2.3.18 external switch power connector(CN8)

power input DC110V,CN8 can output DC110V

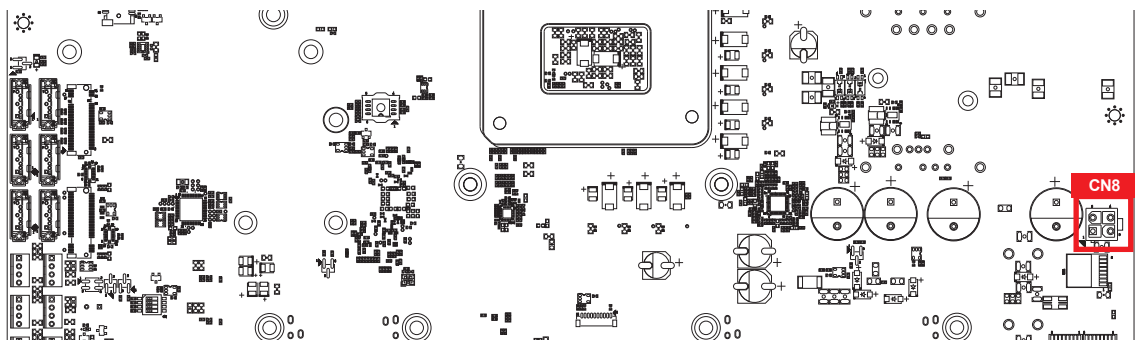

PIN NO.	Definition	Layout
1	GND	
2	GND	
3	+DC110V	
4	+DC110V	

2.4 Main Board Jumper Settings

2.4.1 Board Bottom View of IVX-1000 Main Board with Jumper and DIP Switch

The figure below is the Bottom view of IVX-1000 main board which is the main board. It shows the location of the jumpers and the switches.

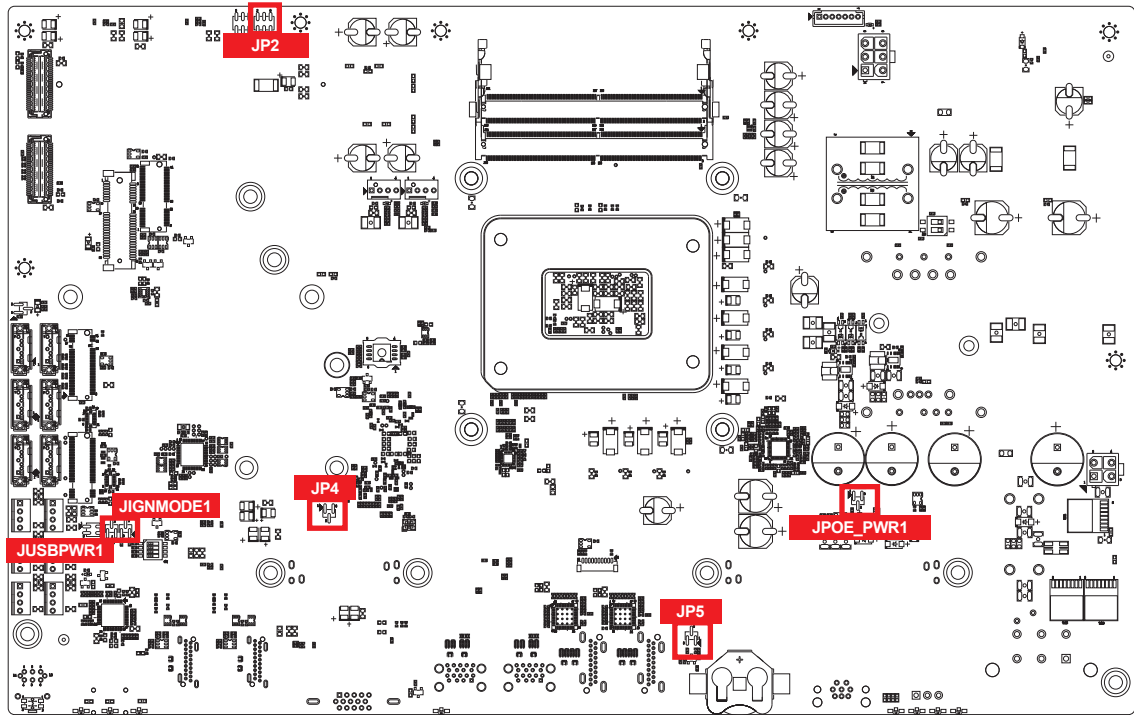

You may configure your card to match the needs of your application by setting jumpers. A jumper is a metal bridge used to close an electric circuit. It consists of two metal pins and a small metal clip (often protected by a plastic cover) that slides over the pins to connect them. To “close” a jumper, you connect the pins with the clip. To “open” a jumper, you remove the clip. Sometimes a jumper will have three pins, labeled 1, 2 and 3. In this case you would connect either pins 1 and 2, or 2 and 3.

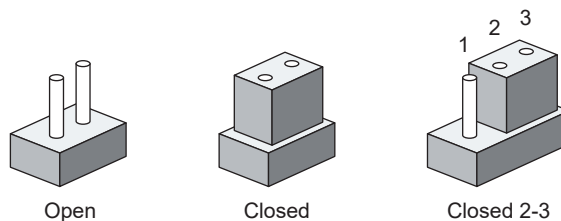

You may configure your card to match the needs of your application by DIP switch. As below show the DIP switch on and off.

You may configure your card to match the needs of your application by DIP switch. As below show the DIP switch on and off.

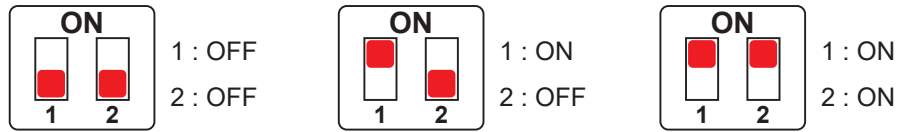

2.4.2 USB Power Jumper (JUSBPWR1)

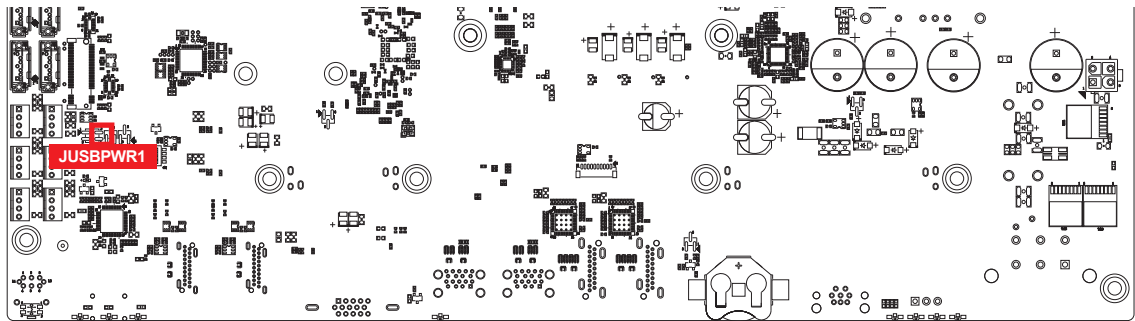

Jumper	Setting	Function	Layout
JUSBPWR1	1:2	Supported Wake Up(Default)	
	2:3	Non Wake Up support	

2.4.3 PoE Power ON Select(JPOE_PWR1)

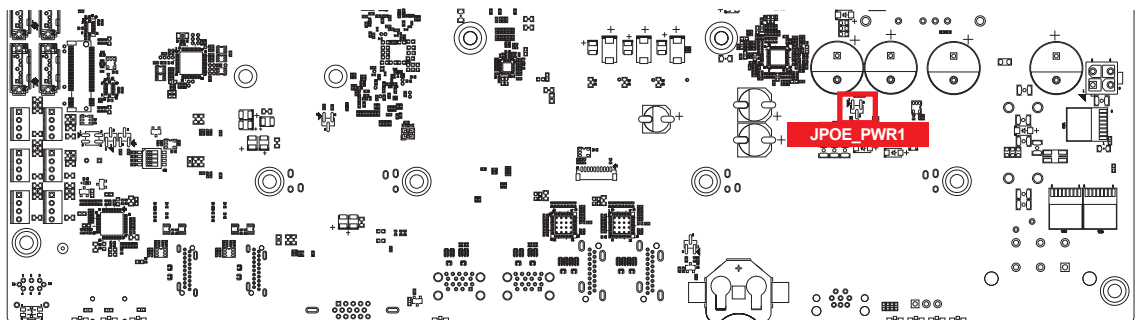

Location	Setting	Function	Layout
JPOE_PWR1	1 - 2	PoE power on at standby power ready	
	2 - 3	PoE power on after system power on(Default)	
	No Jumper	Disable PoE power	

2.4.4 MXM VGA Disable (JP2)

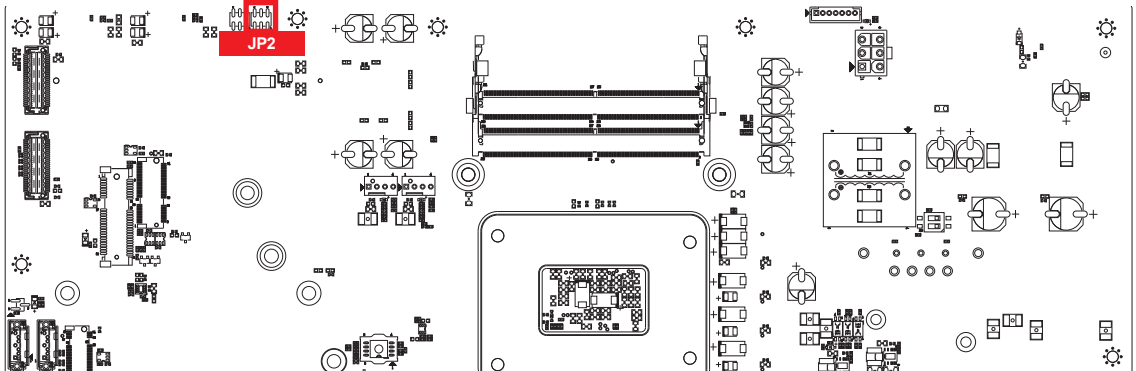

Jumper	Setting	Function	Layout
JP2	1:3	MXM VGA Enable(Default)	
	3:5	MXM VGA Disable	

2.4.5 Clear CMOS(JP5)

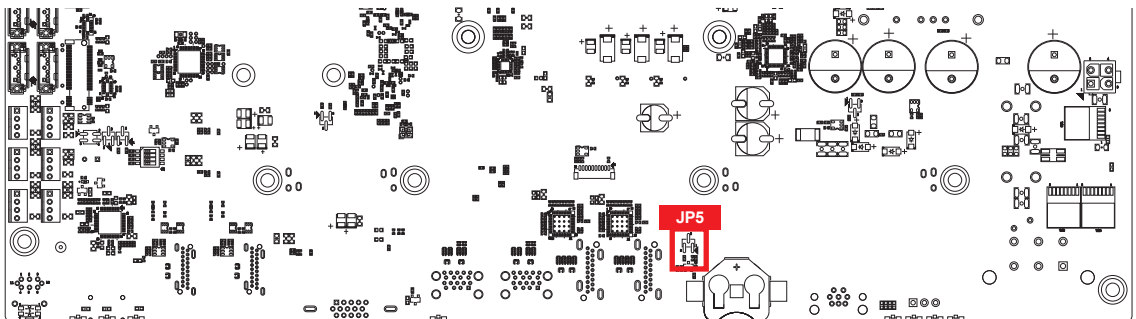

Jumper	Setting	Function	Layout
JP5	1:2	*Normal(Default)	
	2:3	Clear CMOS	

2.4.6 HDA_SDO1(JP4)

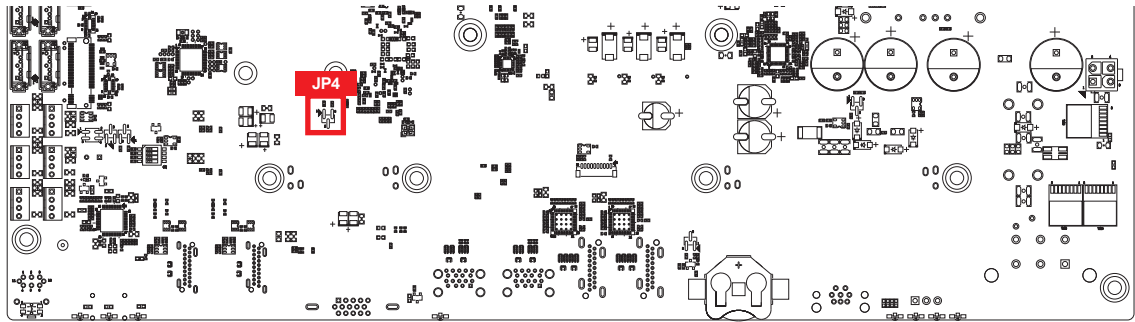

Jumper	Setting	Function	Layout
JP4	1:2	*Enable security measures defined in the Flash Descriptor. (Default)	
JP4	2:3	Disable Flash Descriptor Security (override)	

2.4.7 IGNITION mode (JIGNMODE1)

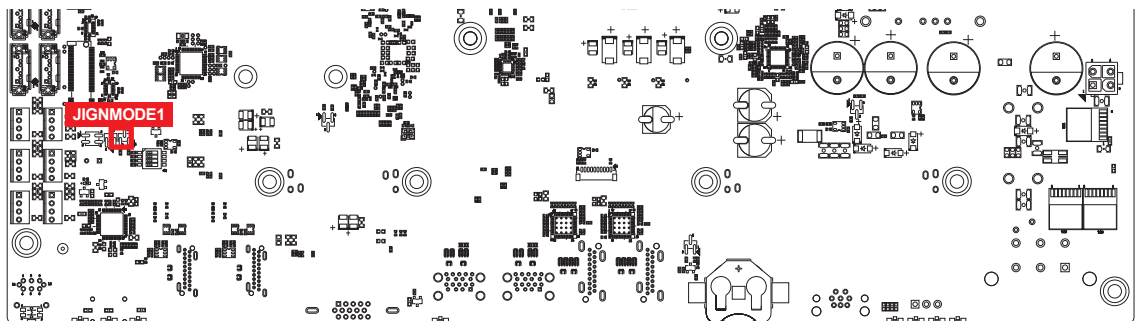

Location	Setting	Function	Layout
JIGNMODE1	1 - 2	H/W mode	
	2 - 3	S/W mode(default)	





2.5 Ignition Control

IVX-1000 series provides ignition power control feature for in-vehicle applications. The built-in MCU monitors the ignition signal and turns on/off the system according to pre-defined on/off delay period.

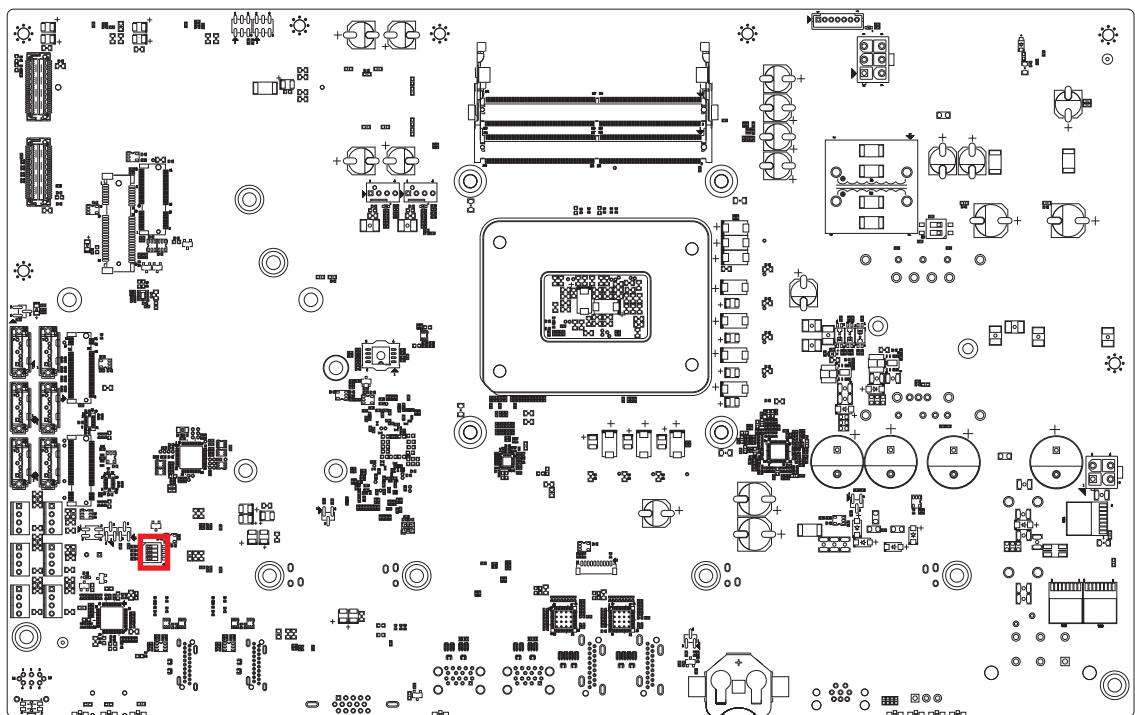
2.5.1 Adjust Ignition Control Modes

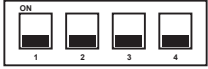
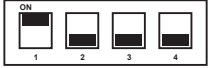
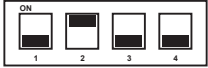
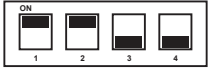
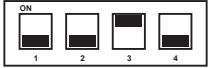
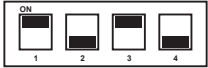
IVX-1000 series provides 16 modes of different power on/off delay periods adjustable via SW1 switch. The default rotary switch is set to 0 in ATX/AT power mode.

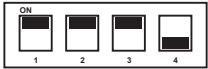
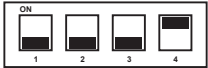
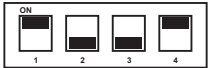
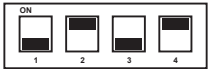
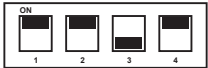

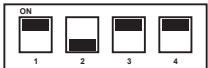
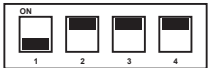
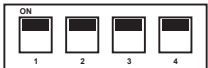
Item	Power On Delay	Power Off Delay	Switch Position
0	ATX/AT mode (Default)		
1	No delay	No delay	
2	No delay	5 seconds	
3	No delay	10 seconds	
4	No delay	30 seconds	
5	5 seconds	60 seconds	
6	5 seconds	10 seconds	
7	5 seconds	30 seconds	
8	5 seconds	60 seconds	
9	5 seconds	90 seconds	
A	10 seconds	120 seconds	
B	10 seconds	10 seconds	
C	10 seconds	30 seconds	
D	10 seconds	60 seconds	
E	10 seconds	90 seconds	
F	10 seconds	120 seconds	

2.6.2 Ignition Control Wiring

To activate ignition control, you need to provide IGN signal via the 3-pin pluggable terminal block located in the back panel. Please find below the general wiring configuration.

Pin No.	Definition
1	Ignition (IGN)
2	SW+
3	SW-

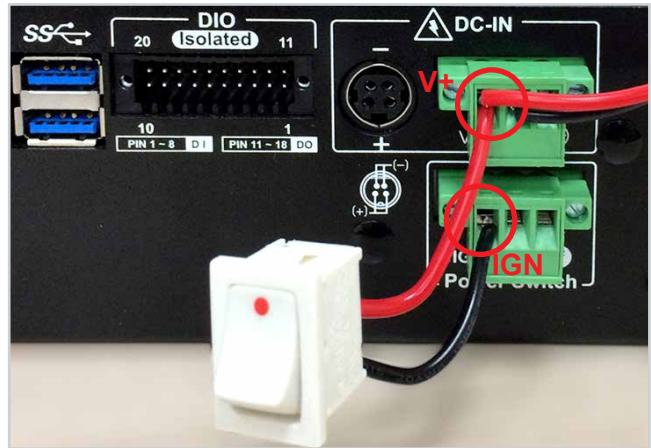

For testing purpose, you can refer to the picture below to simulate ignition signal input controlled by a latching switch.

Note :

1. DC power source and IGN share the same ground.
2. IVX-1000 supports 16V to 160V wide range DC power input in ATX/AT mode. In Ignition mode, the input voltage is fixed to 12V/24V for car battery scenario.
3. For proper ignition control, the power button setting should be "Power Down" mode.

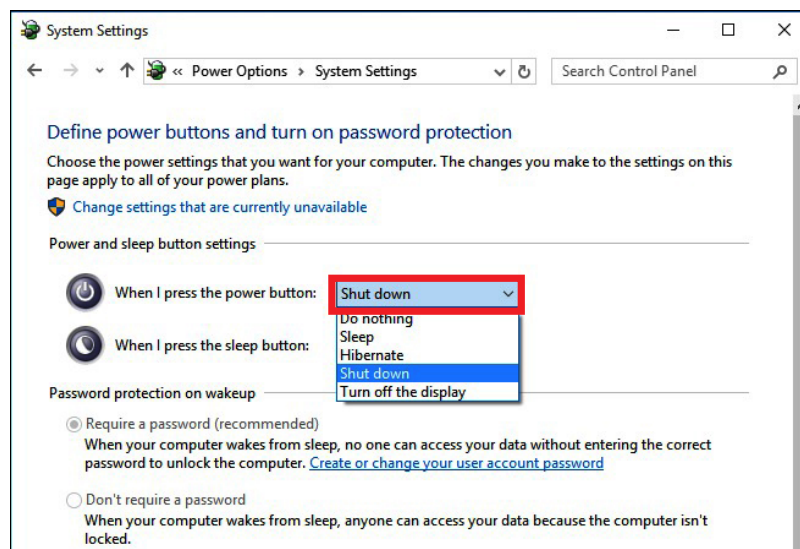

In Windows for example, you need to set "When I press the power button" to Shut down.

3

SYSTEM SETUP

3.1 How to Open Your IVX-1000

Step 1 Remove F-M3x4L screw. 5PCS

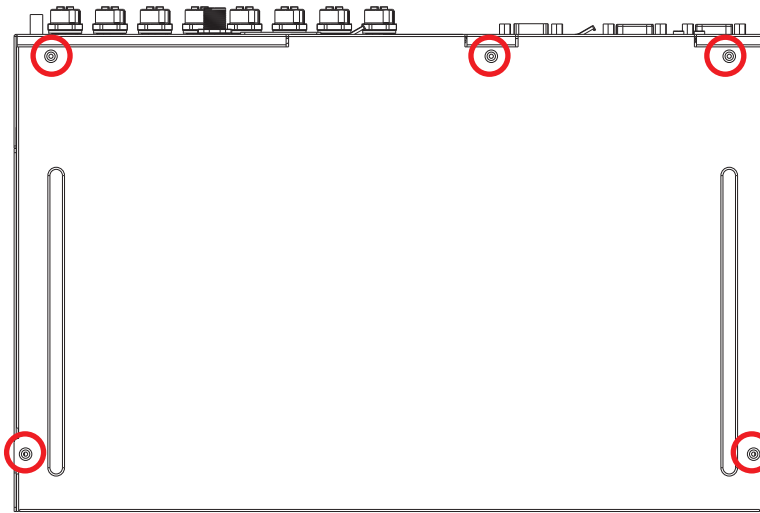

Step 2 Open Your IVX-1000

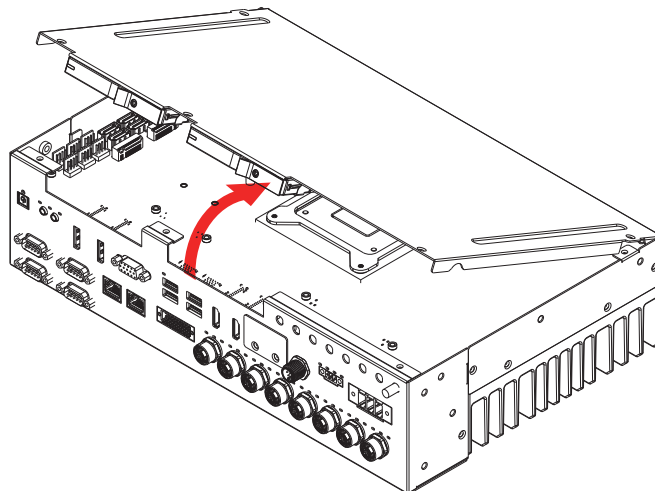

3.2 Installing CPU

Step 1 Remove six I-M3x6L screws.

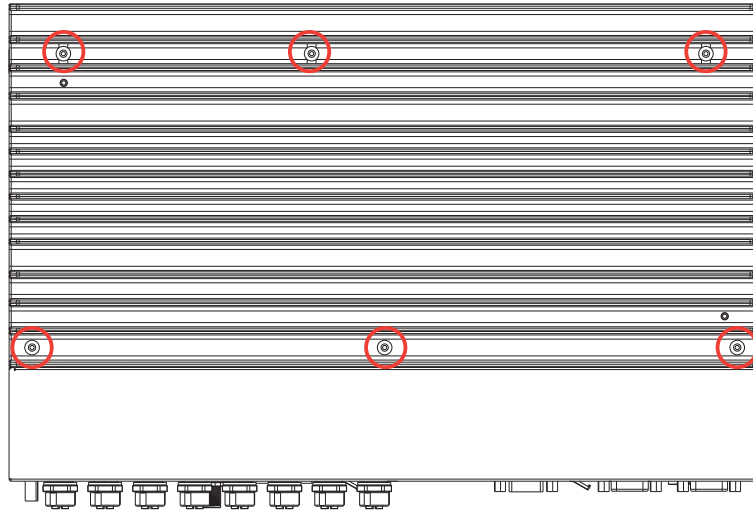

Step 2 Remove Sink & Find CPU socket.

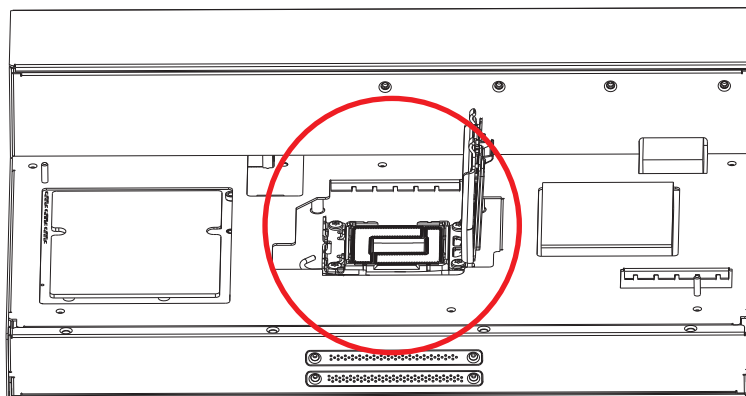

Step 3 Installing CPU.

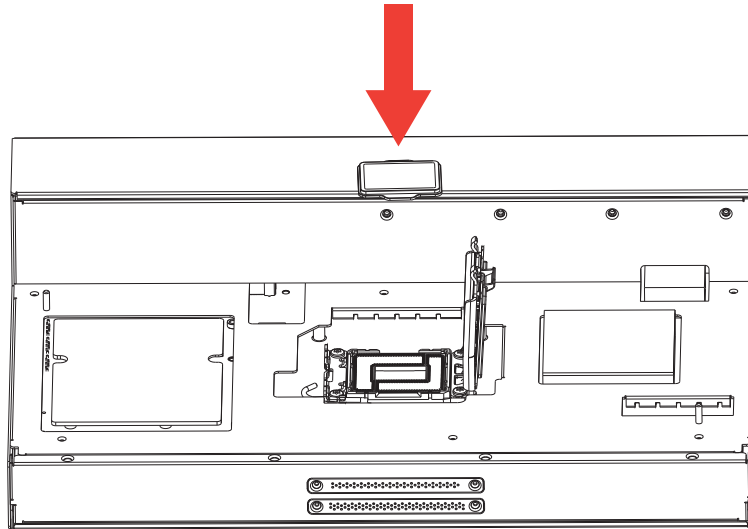

Step 4 align with the positioning hole

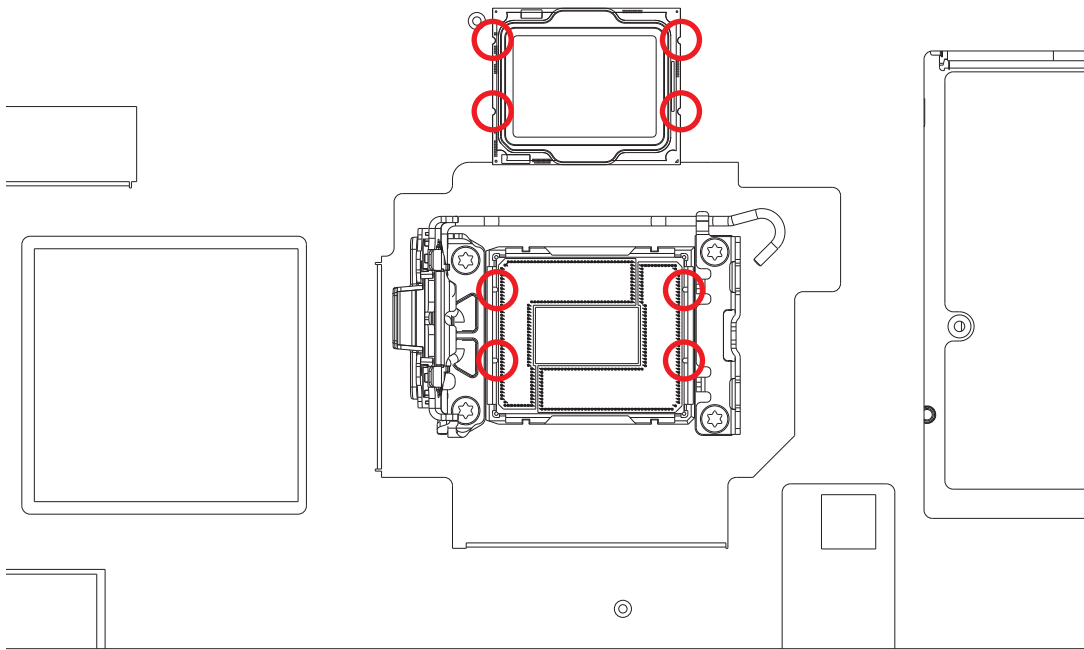

Step 5 Remove cover

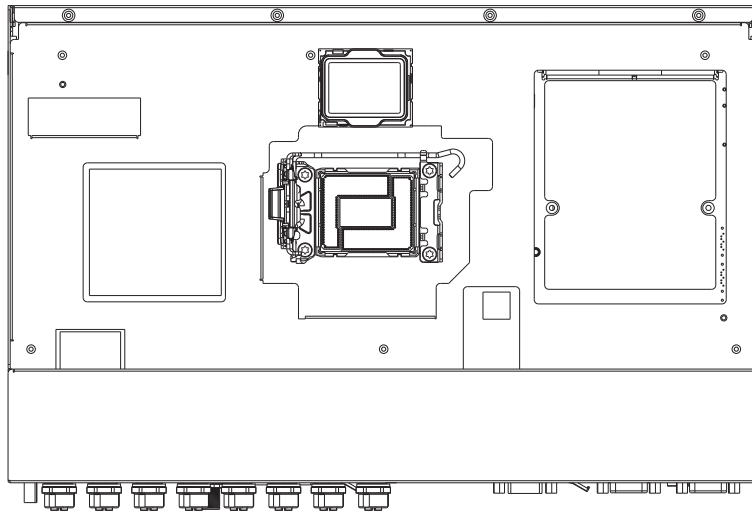

3.3 Installing DDR5 SO-DIMM Modules

Step 1 Remove the 4PCS M3 screws and remove the sink.

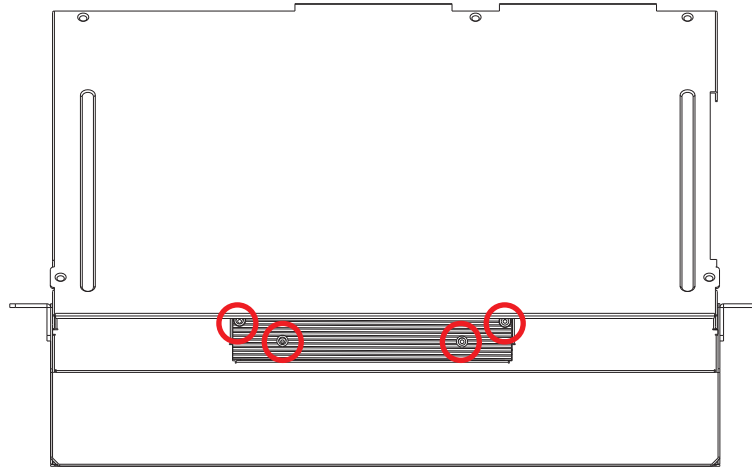

Step 2 Remove the 2PCS M3 screws and remove the copper plate.

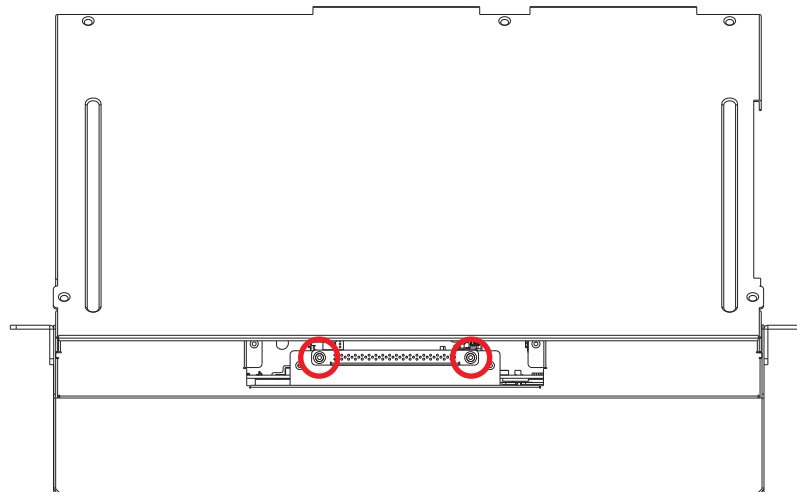

Step 3 Remove the 4PCS screws and remove the aluminum block.

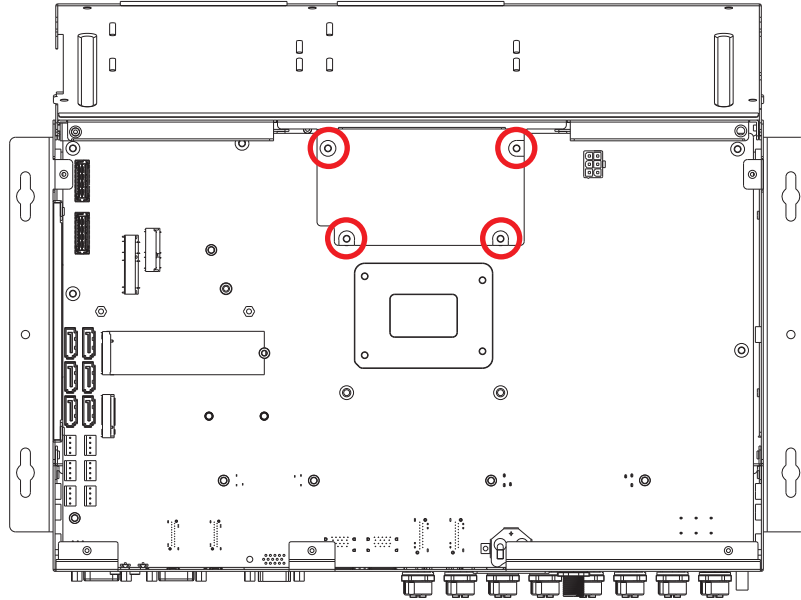

Step 4 Install DDR5 RAM module into SO-DIMM slot.

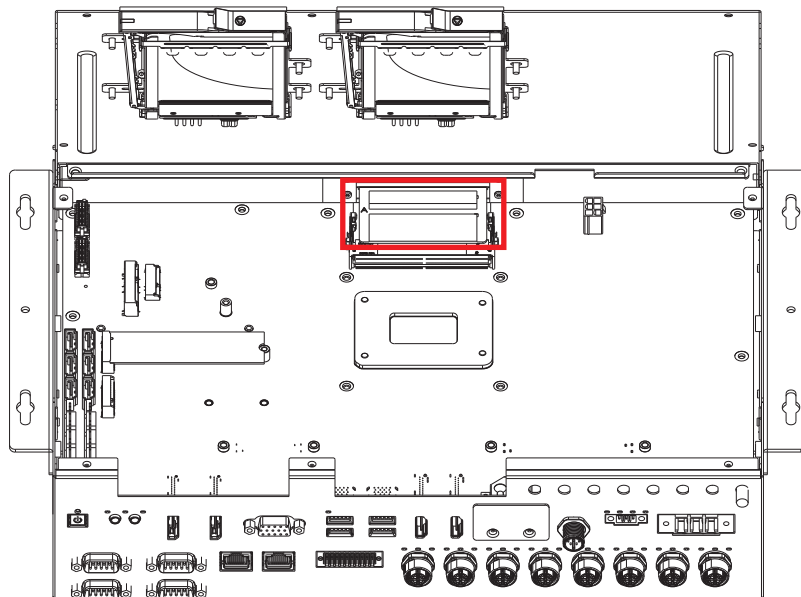

Step 5 Install copper block A from the rear panel and secure it with two M3 X 4L flathead screws.

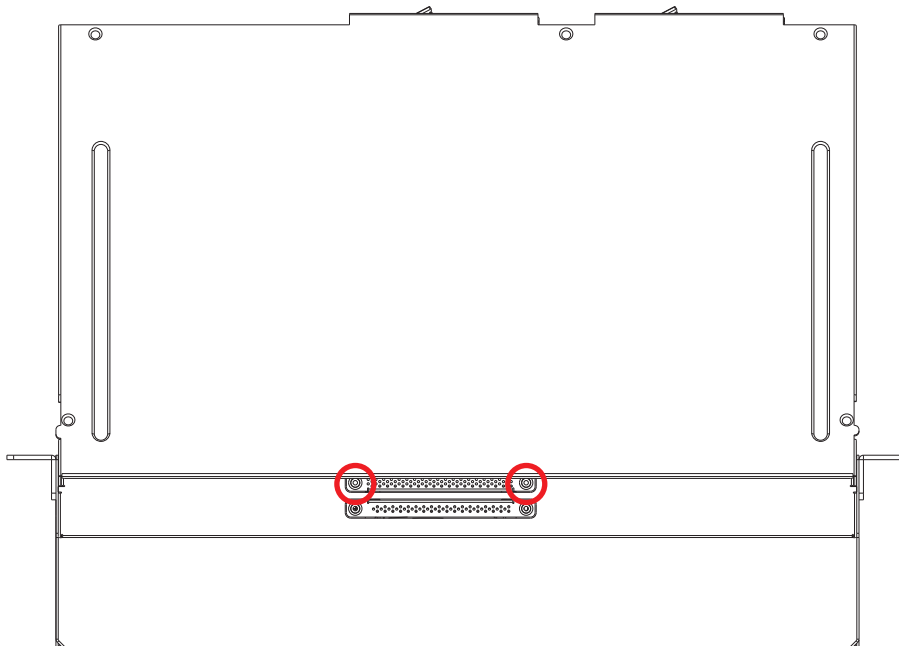
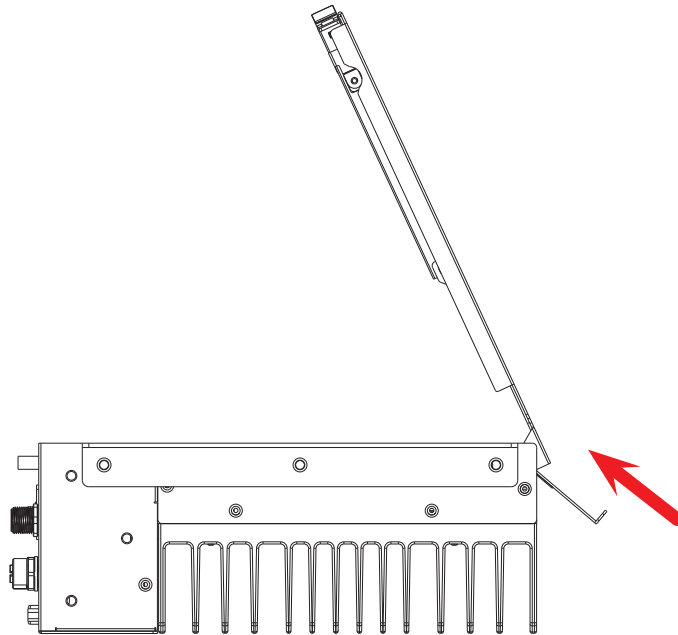

Step 6 Install the second DDR5 module into SO-DIMM slot.

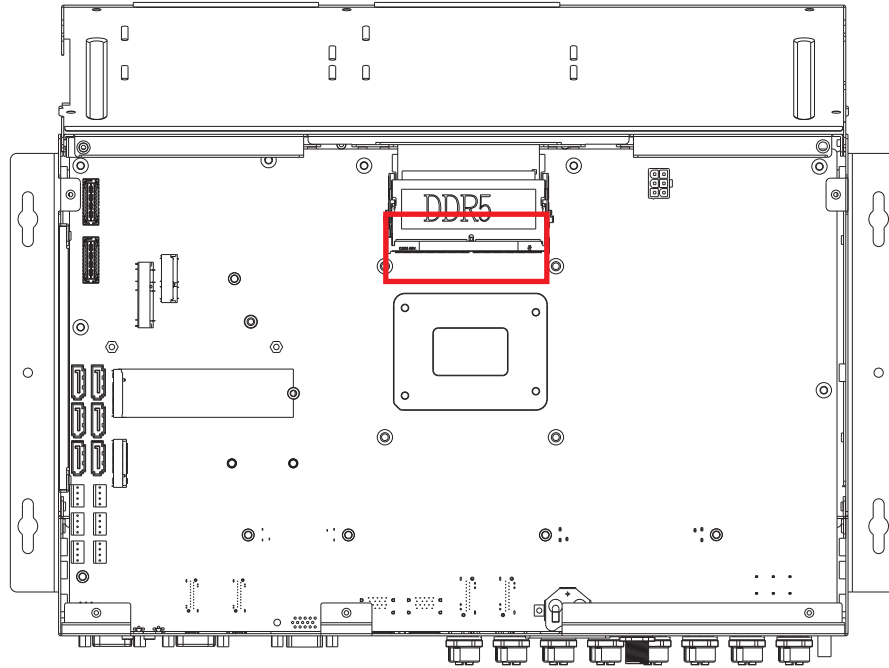

Step 7 Install the aluminum block and tighten the 4 PCS M3 screws.

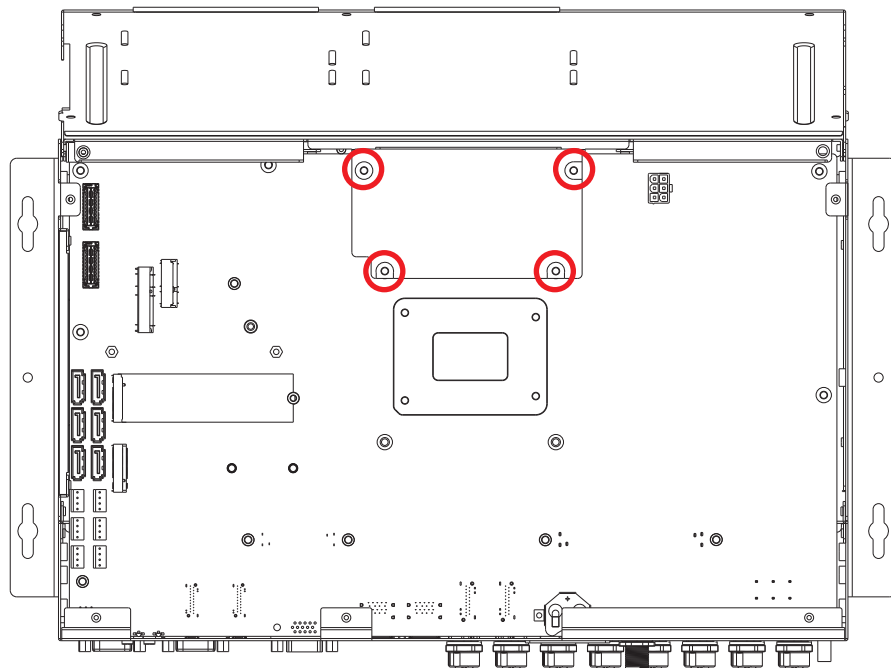

3.4 Installing Mini PCIe Card

Step 1 Install Mini PCIe card into the Mini PCIe slot.

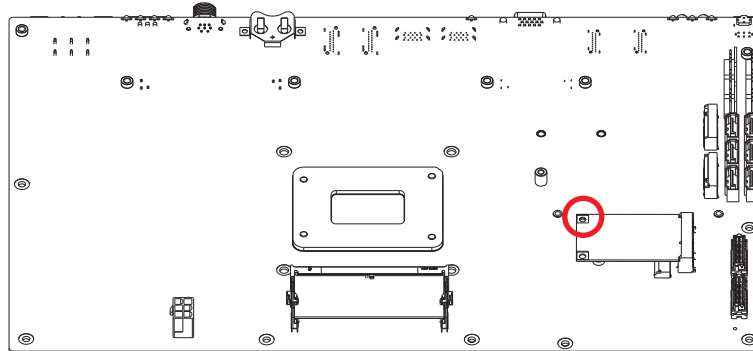
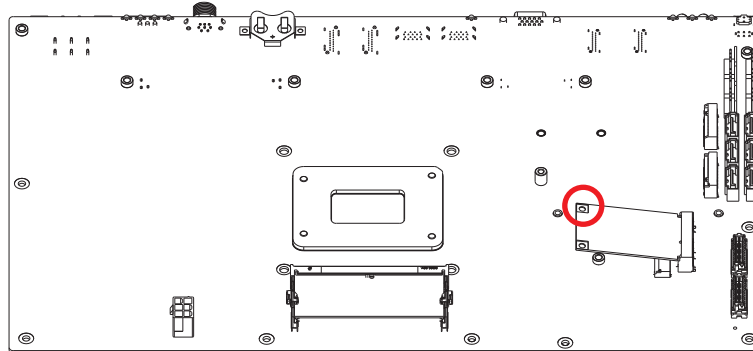
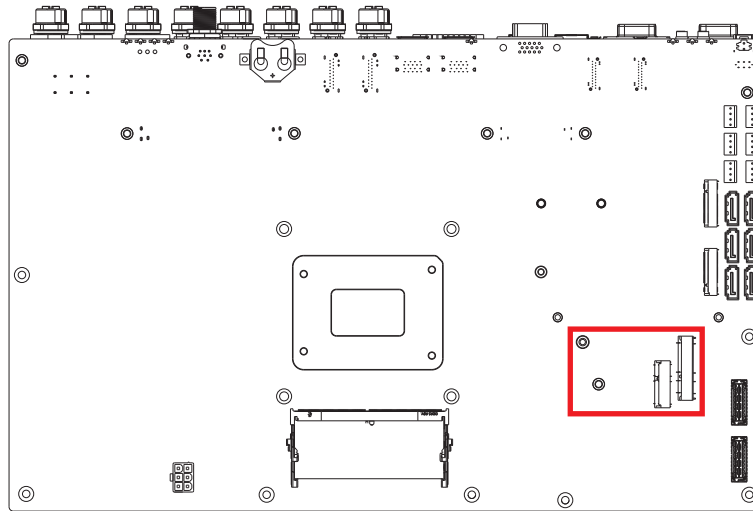

3.5 Installing Nano SIM Card

Step 1 Remove two F-M3x4L screws on SD & SIM cover.

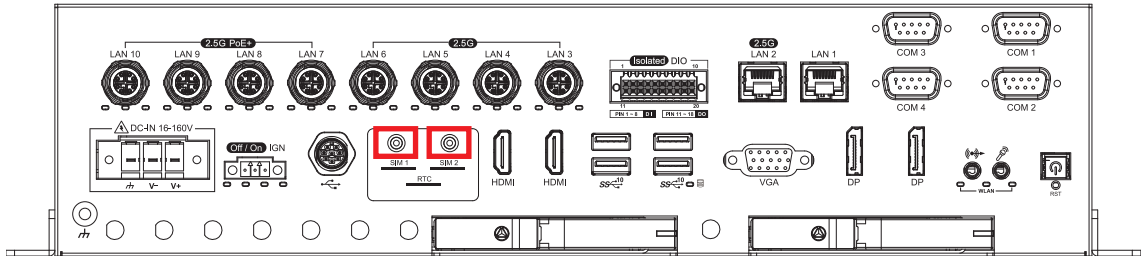

Step 2 Inserting SIM Card, make sure the system power is not plugged.

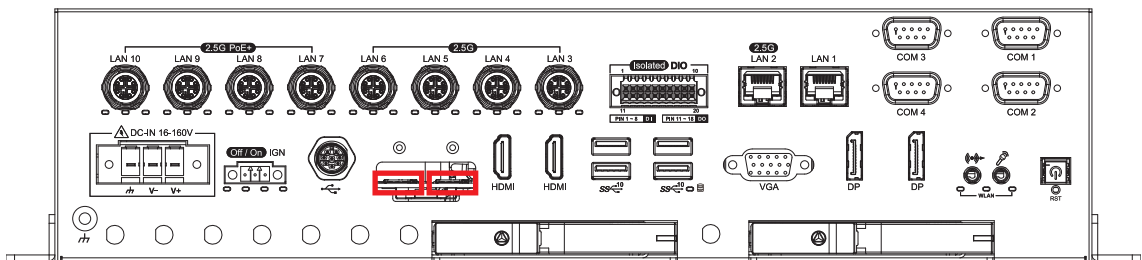

3.6 Installing SSD/HDD

3.6.1 IVX-1000

Step 1 Trigger and open SSD/HDD tray.

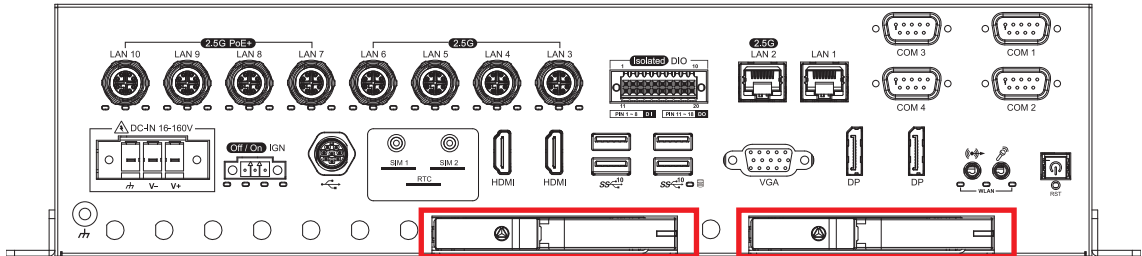

Step 2 Installing SSD/HDD.

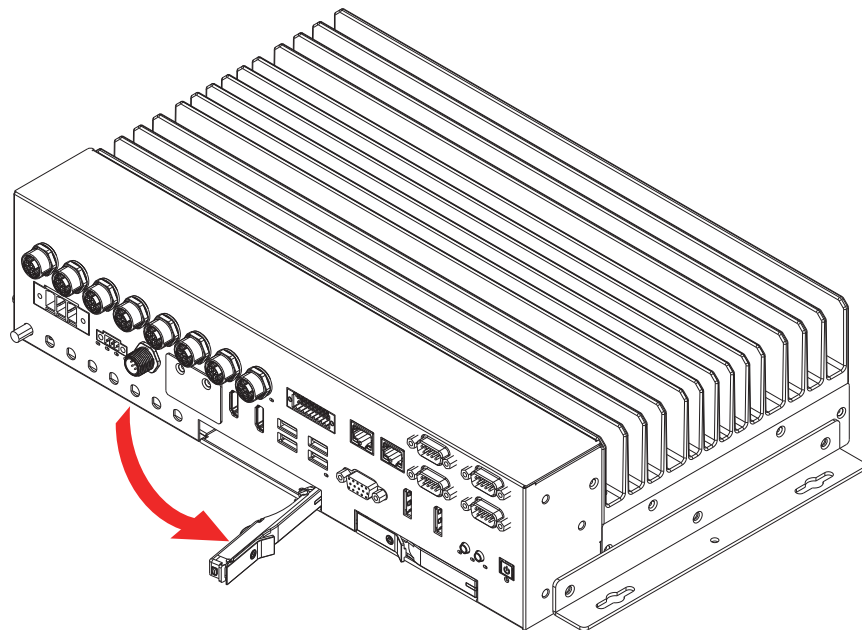

Step 3 Turn the key to the right to lock the SDD tray

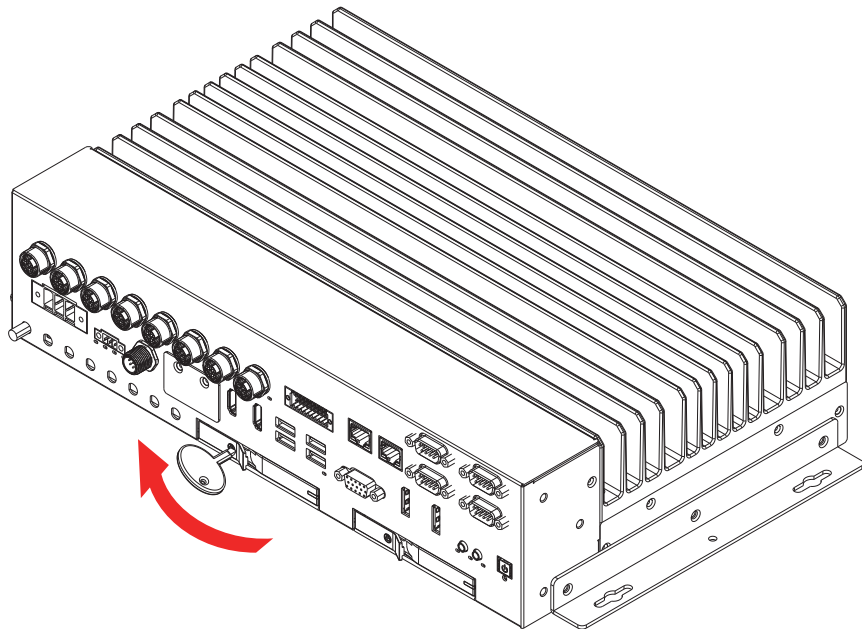
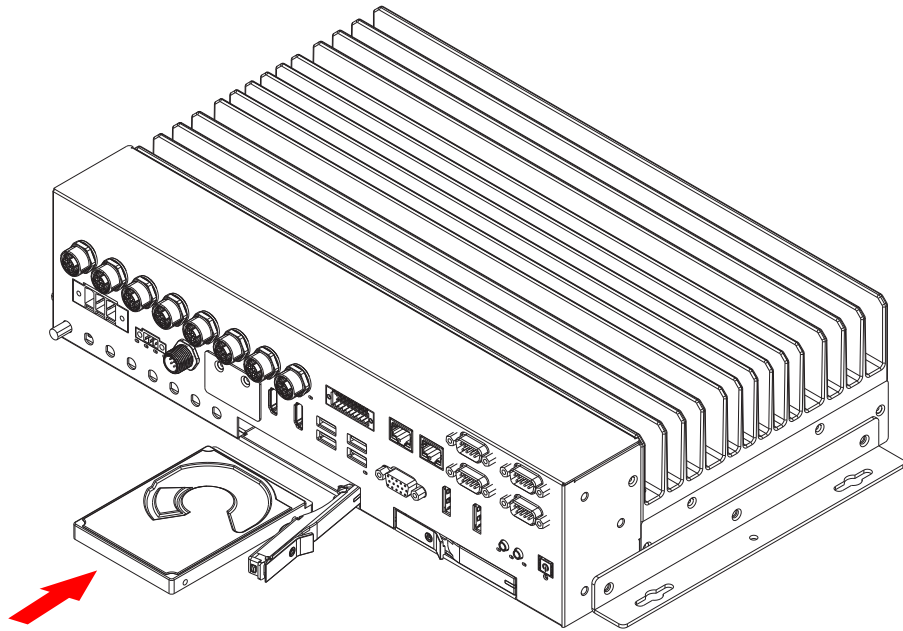

3.6.2 IVX-1000-ICY

Step 1 Trigger and open SSD/HDD tray.

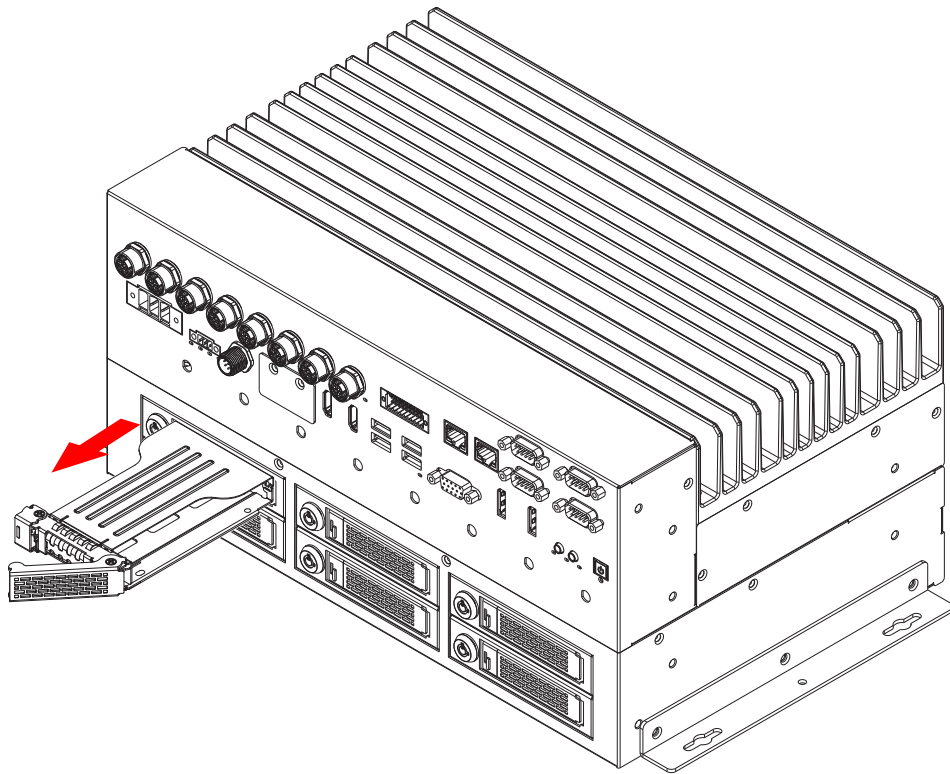
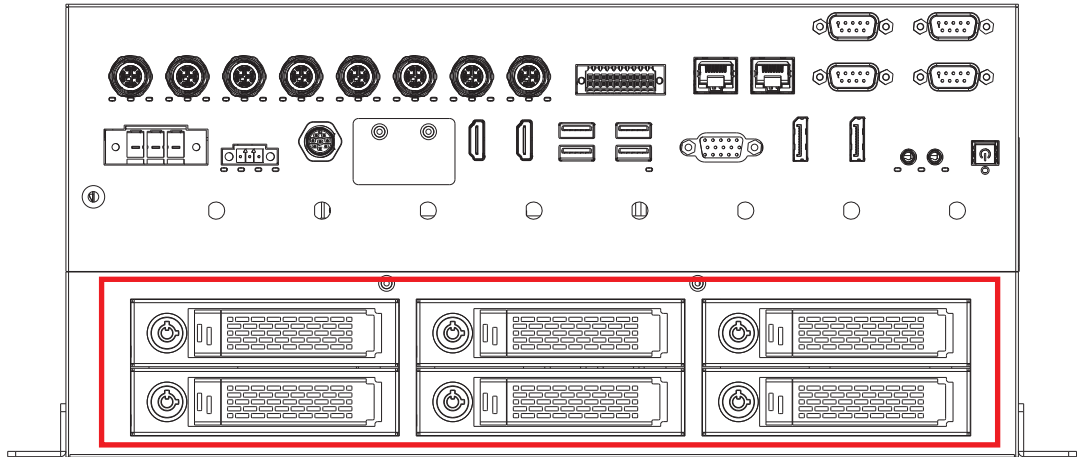

Step 2 Use M3*4 flat X4 head screws to secure the SSD onto the tray

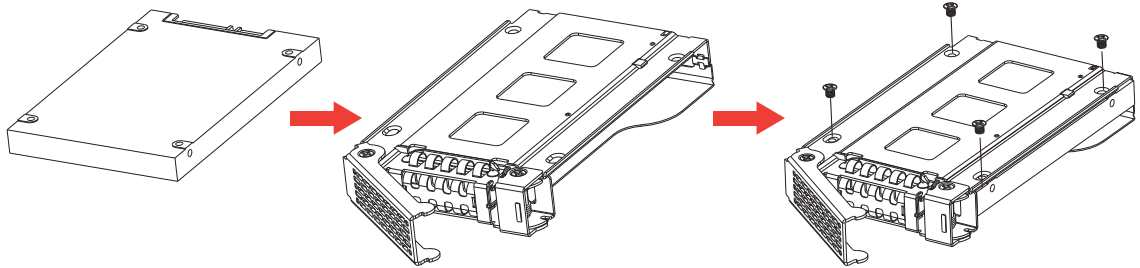

Step 3 Turn the key to the right to lock the SDD tray

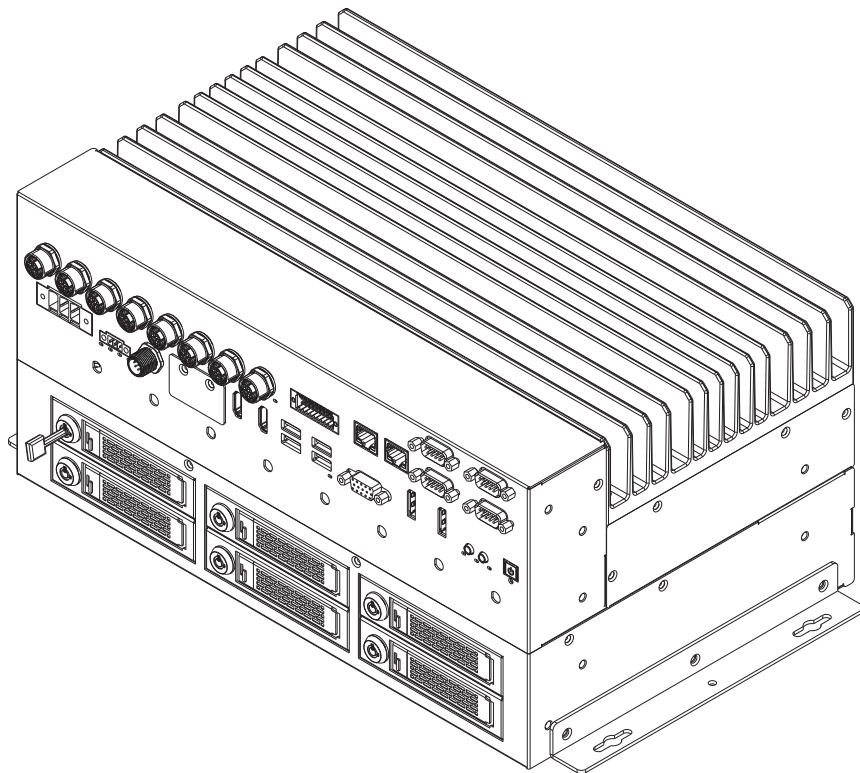

3.7 Installing M.2

Key B 2280 , Key E 2230 , Key M 2280

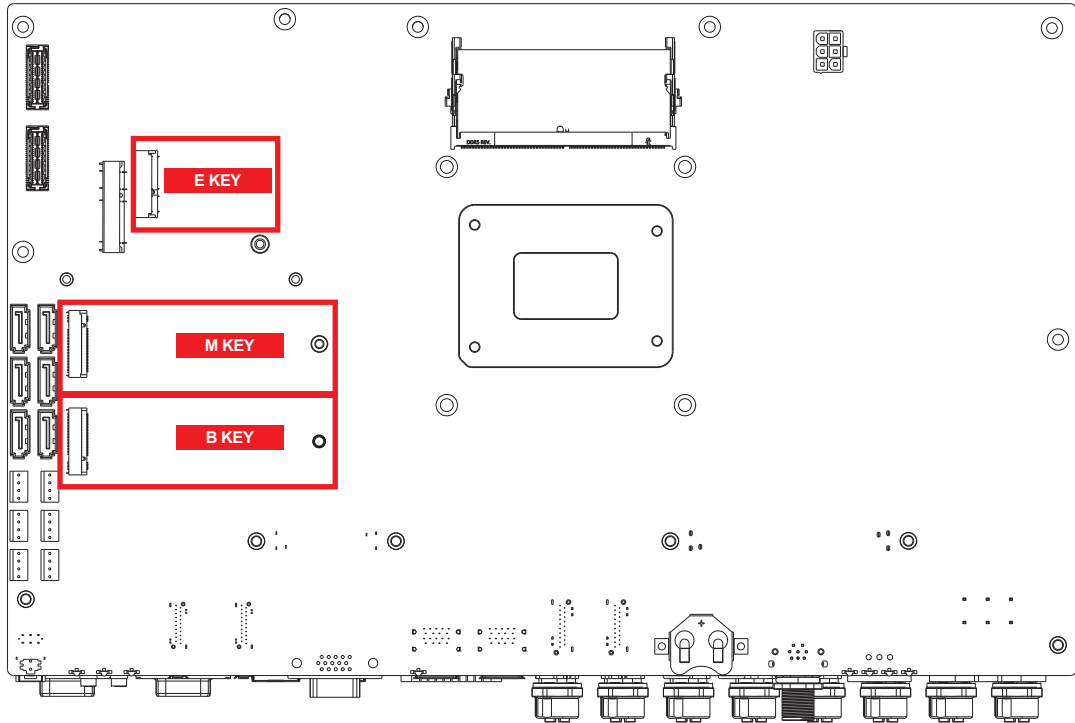

Step 1 Remove the 4 PCS screws and remove the copper plate and sink.

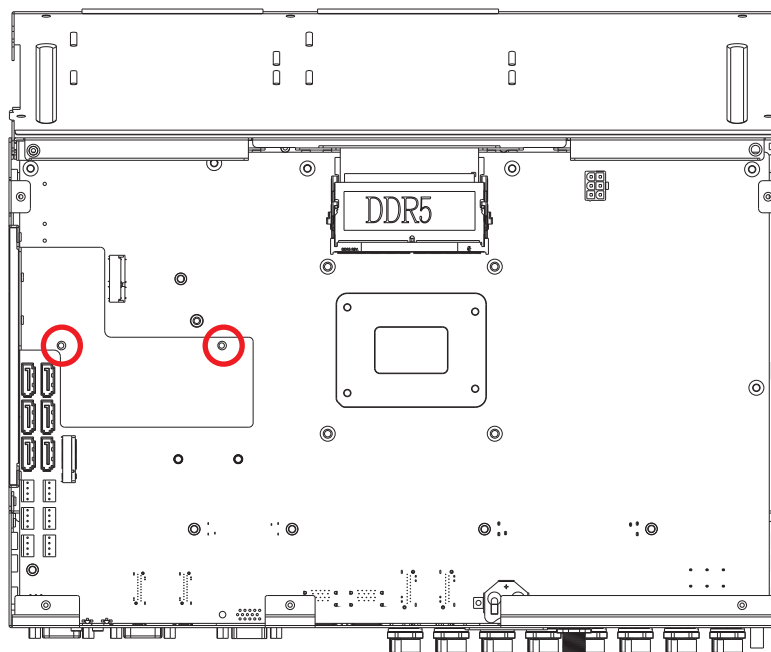

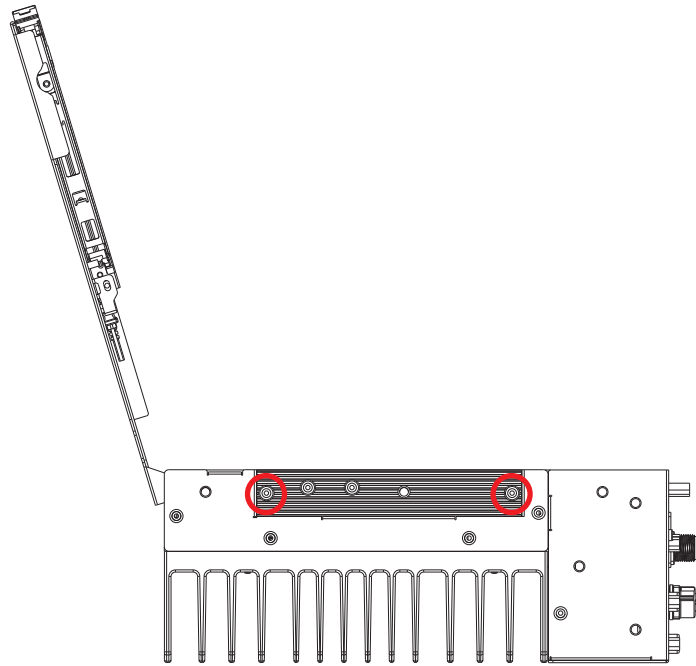

Step 2 Install the M2 module.

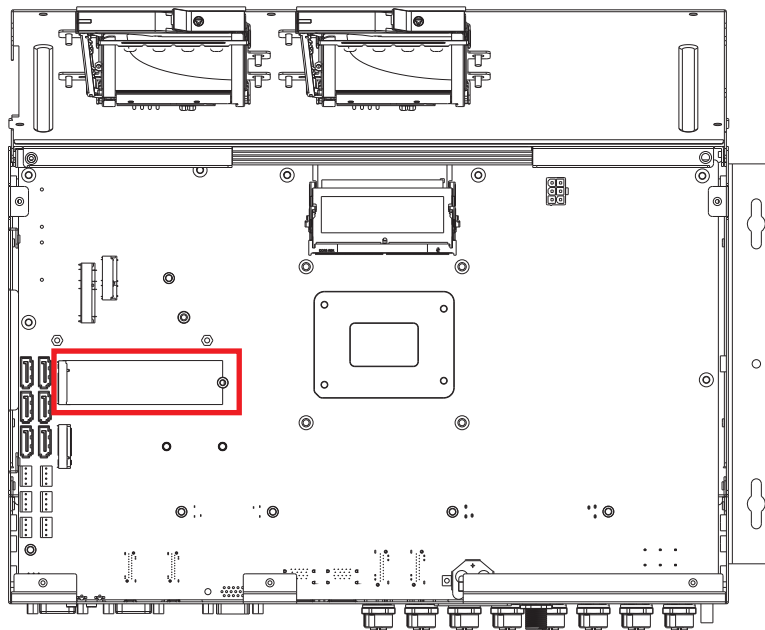

Step 3 Tighten the 4 screws to secure the copper plate and sink.

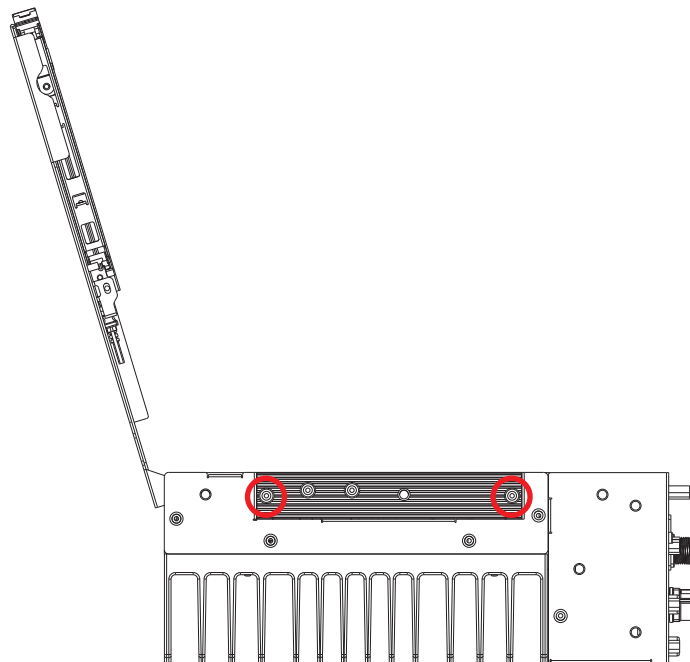
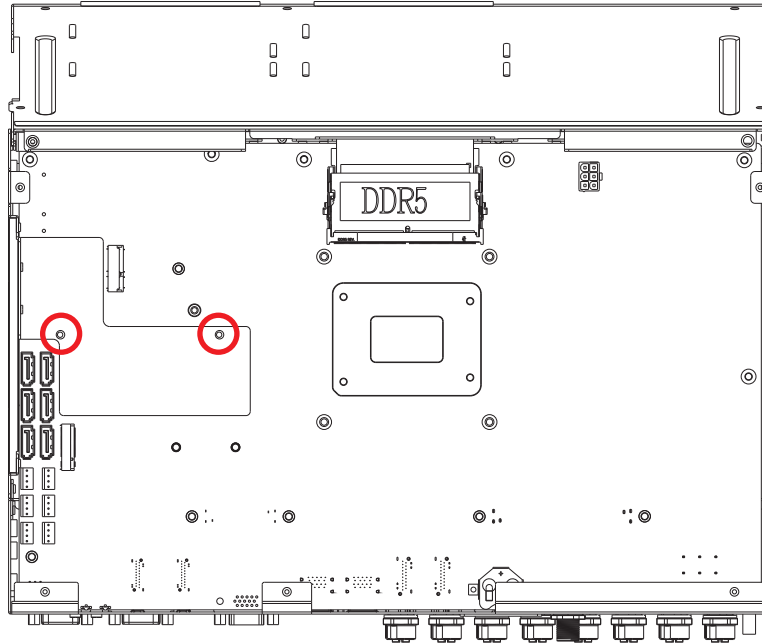

3.8 Installing Antenna Cable

Step 1 Remove the rubber corks on the front and side.

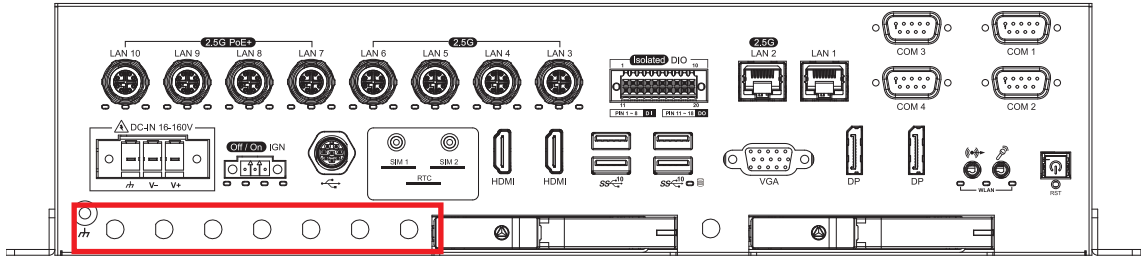

Step 2 Check antenna parts (cable and washers).



Step 3 Fasten washer 1, washer 2, and on Antenna cable connector .

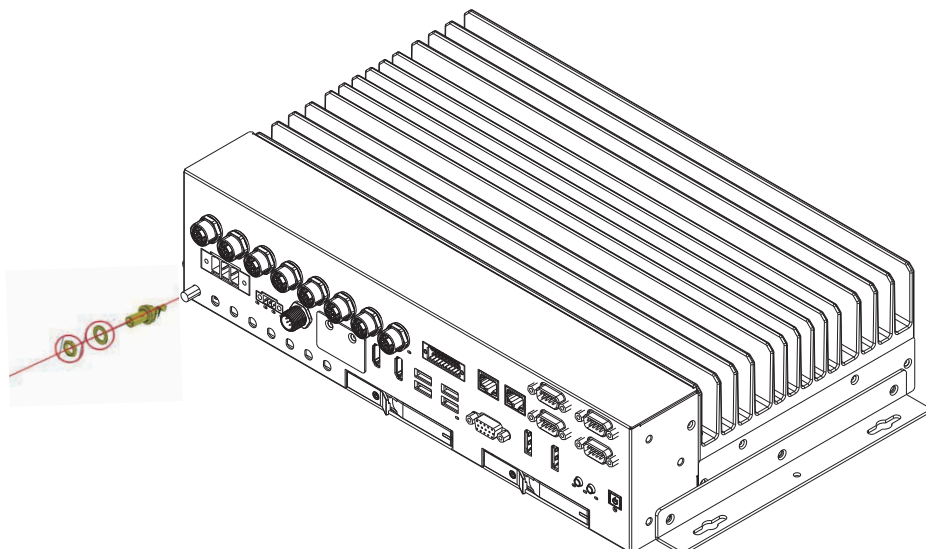

3.9 Mount Your IVX-1000

3.9.1 IVX-1000

Wall Mount Bracket for IVX-1000 with four M4x6L screws.

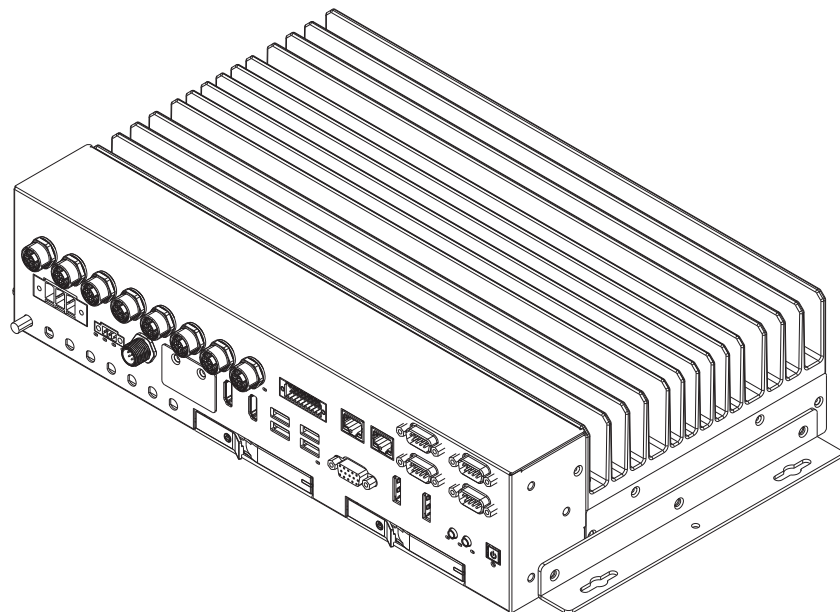
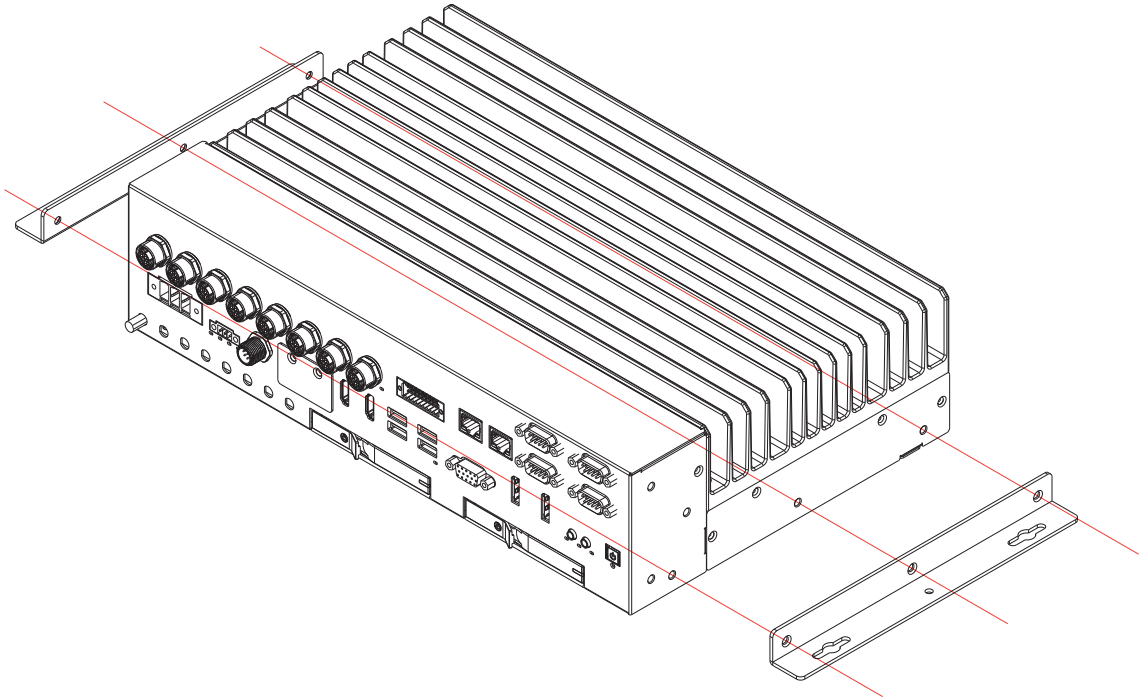

3.9.2 IVX-1000-ICY

Wall Mount Bracket for IVX-1000-ICY with four M4x6L screws.

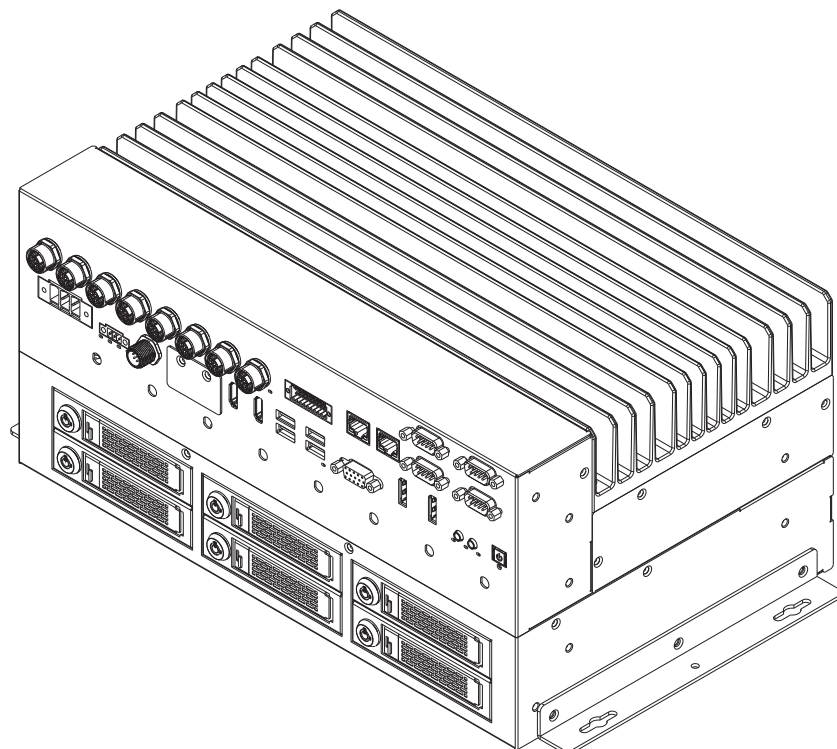
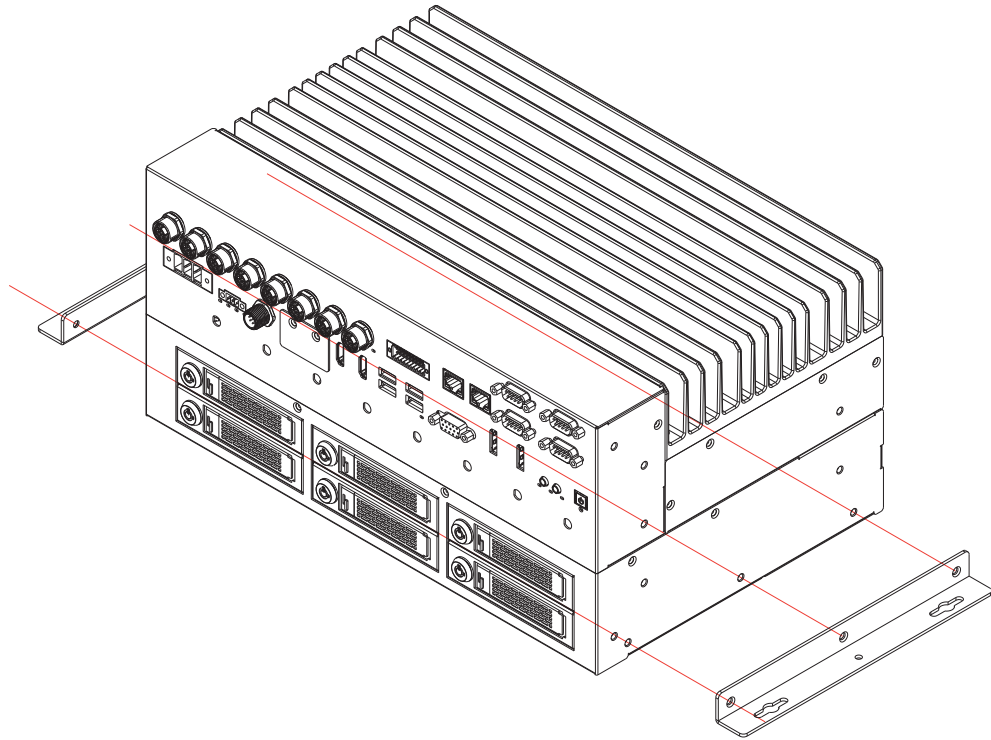

4

BIOS AND DRIVER

4.1 BIOS Setup

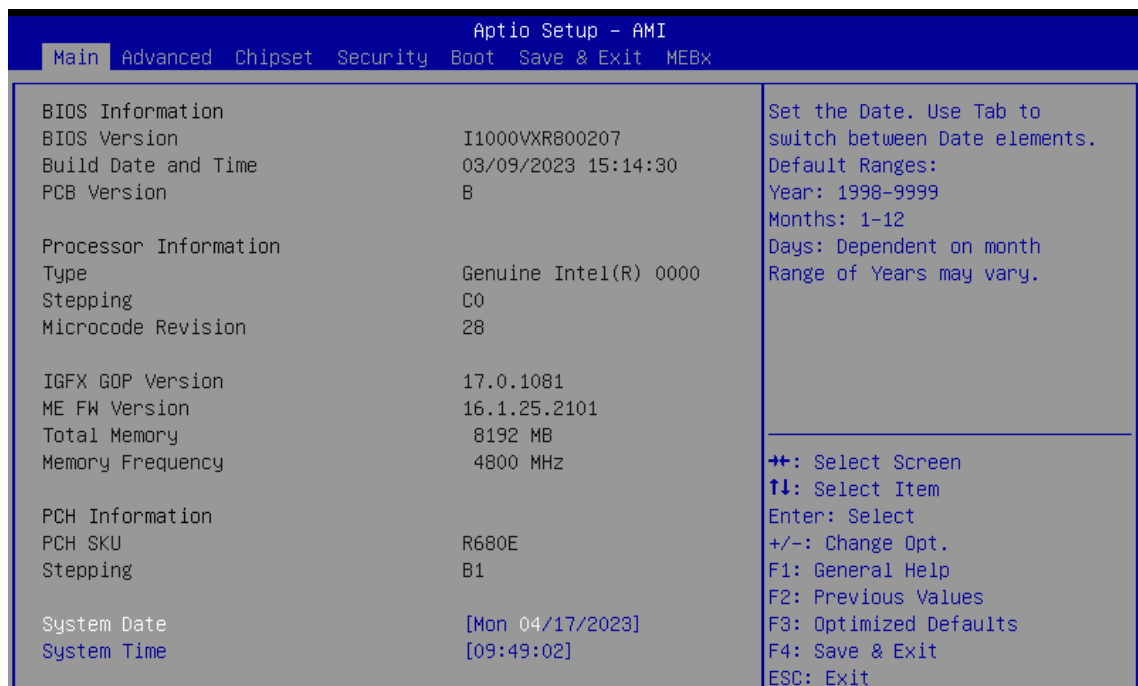

Figure 4-1 : Entering Setup Screen

BIOS provides an interface for users to check and change system configuration. The BIOS setup program is accessed by pressing the key when POST display output is shown.

4.2 Main Menu

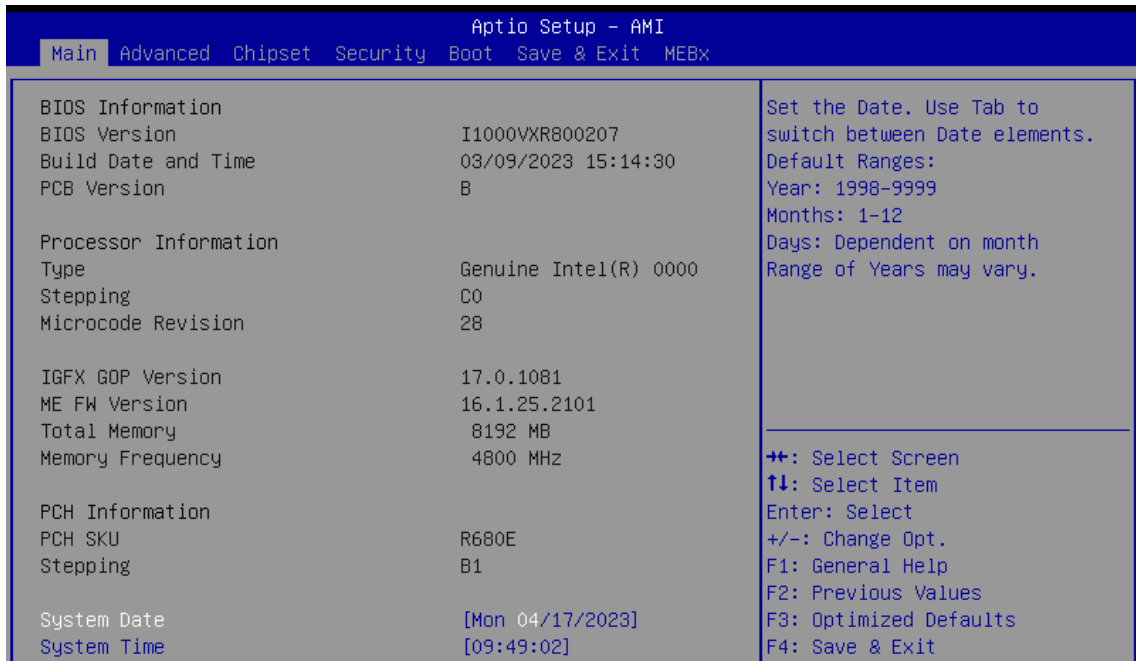

Figure 4-2 : BIOS Main Menu

The main menu displays BIOS version and system information. There are two options on Main menu.

System Date

Set the Date. Use Tab to switch between Date elements.

Default Ranges:

Year: 1998-9999

Months: 1-12

Days: Dependent on month

Range of Years may vary.

System Time

Set the Time. Use Tab to switch between Time elements.

4.3 Advanced Function

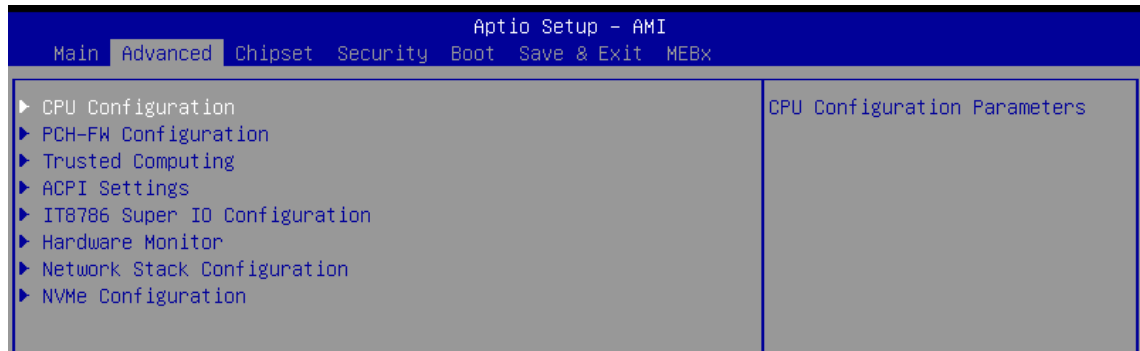

Figure 4 3: BIOS Advanced Menu

Select advanced tab to enter advanced BIOS setup options, such as CPU configuration, ACPI settings, and Super IO configuration.

4.3.1 CPU Configuration

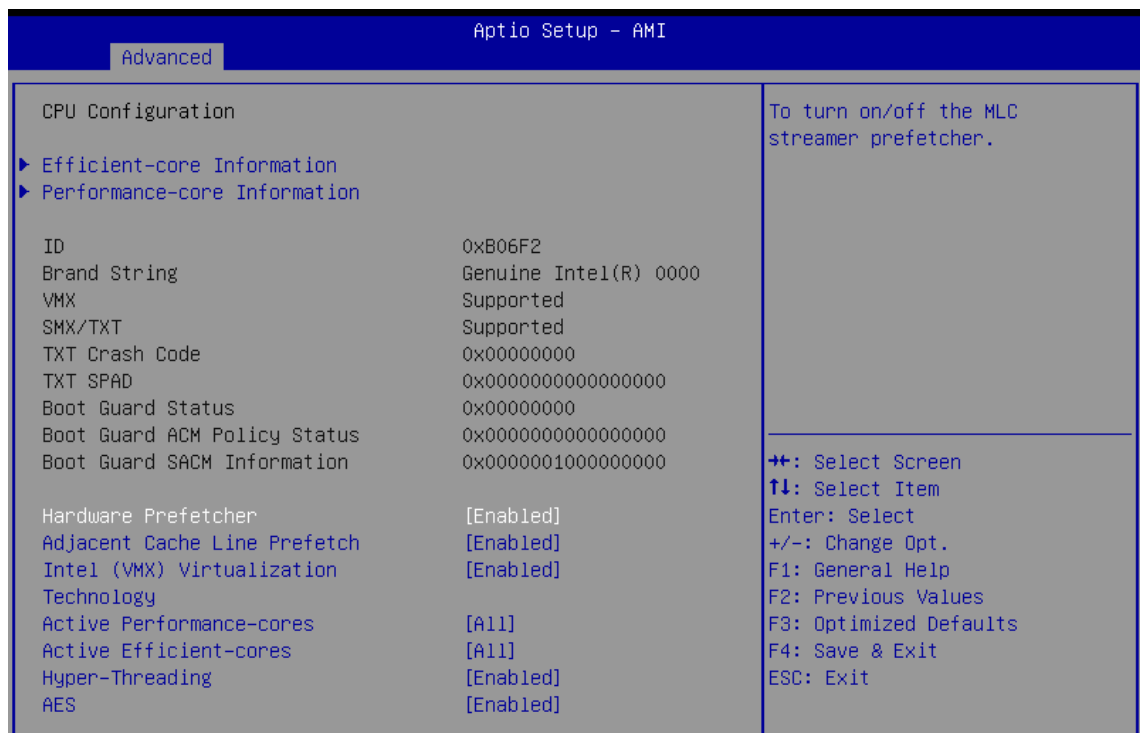

Figure 4 3-1: CPU Configuration

Efficient-core Information

Displays the E-core Information.

Performance-core Information

Displays the P-core Information.

Hardware Prefetcher

To turn on/off the MLC streamer prefetcher.

Adjacent Cache Line Prefetch

To turn on/off prefetching of adjacent cache lines.

Intel (VMX) Virtualization Technology

When enabled, a VMM can utilize the additional hardware capabilities provided by Vanderpool Technology.

Active Performance-cores

Number of P-cores to enable in each processor package. Note: Number of Cores and E-cores are looked at together. When both are {0,0}, Pcode will enable all cores.

Active Efficient-cores

Number of E-cores to enable in each processor package. Note: Number of Cores and E-cores are looked at together. When both are {0,0}, Pcode will enable all cores.

Hyper-Threading

Enable or Disable Hyper-Threading Technology.

AES

Enable/Disable AES (Advanced Encryption Standard)

4.3.2 PCH-FW Configuration

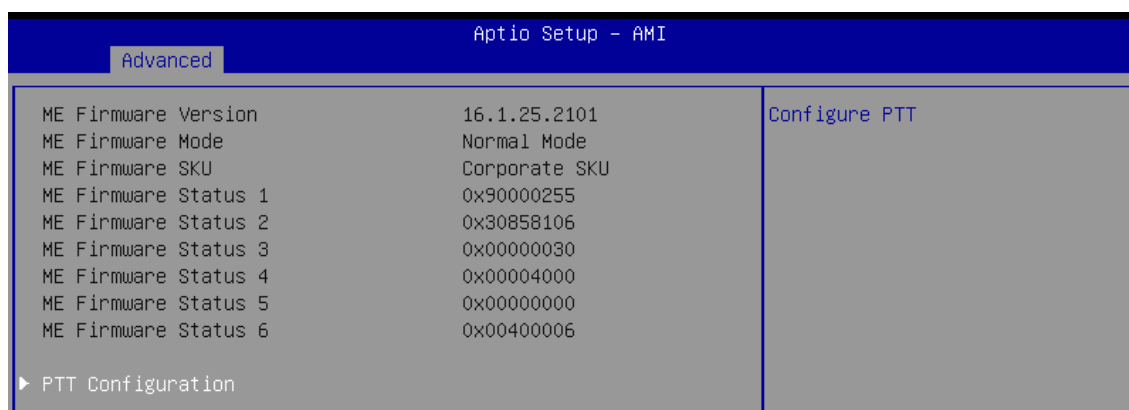

The screenshot shows the 'Advanced' tab of the 'Aptio Setup - AMI' BIOS. The 'ME Firmware' section is expanded, displaying the following information:

ME Firmware Version	16.1.25.2101	Configure PTT
ME Firmware Mode	Normal Mode	
ME Firmware SKU	Corporate SKU	
ME Firmware Status 1	0x90000255	
ME Firmware Status 2	0x30858106	
ME Firmware Status 3	0x00000030	
ME Firmware Status 4	0x00004000	
ME Firmware Status 5	0x00000000	
ME Firmware Status 6	0x00400006	

Below the firmware information, there is a 'PTT Configuration' option with a right-pointing arrow.

Figure 4 3-2: PCH-FW Configuration

PTT Configuration

Configure PTT

4.3.2.1 PTT Configuration

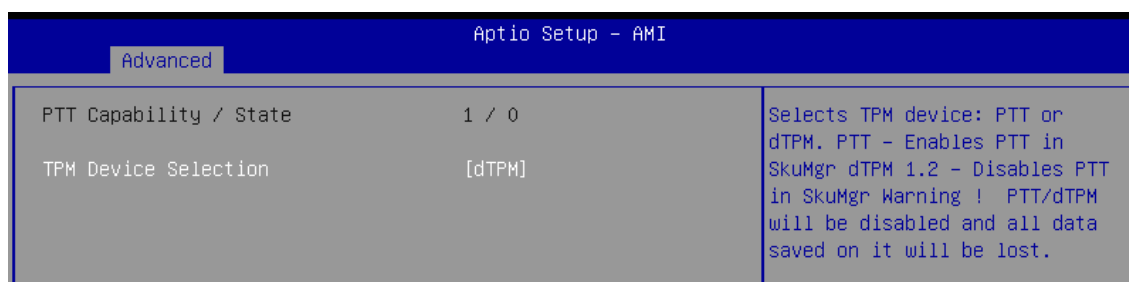

The screenshot shows the 'Advanced' tab of the 'Aptio Setup - AMI' BIOS. The 'PTT Configuration' section is expanded, displaying the following information:

PTT Capability / State	1 / 0	Selects TPM device: PTT or dTPM. PTT - Enables PTT in SkuMgr dTPM 1.2 - Disables PTT in SkuMgr Warning ! PTT/dTPM will be disabled and all data saved on it will be lost.
TPM Device Selection	[dTPM]	

Figure 4 3-2-1: PTT Configuration

TPM Device Selection

Selects TPM device: PTT or dTPM. PTT - Enables PTT in SkuMgr dTPM 1.2 - Disables PTT is SkuMgr Warning! PTT/dTPM will be disabled and all data saved on it will be lost.

4.3.3 Trusted Computing

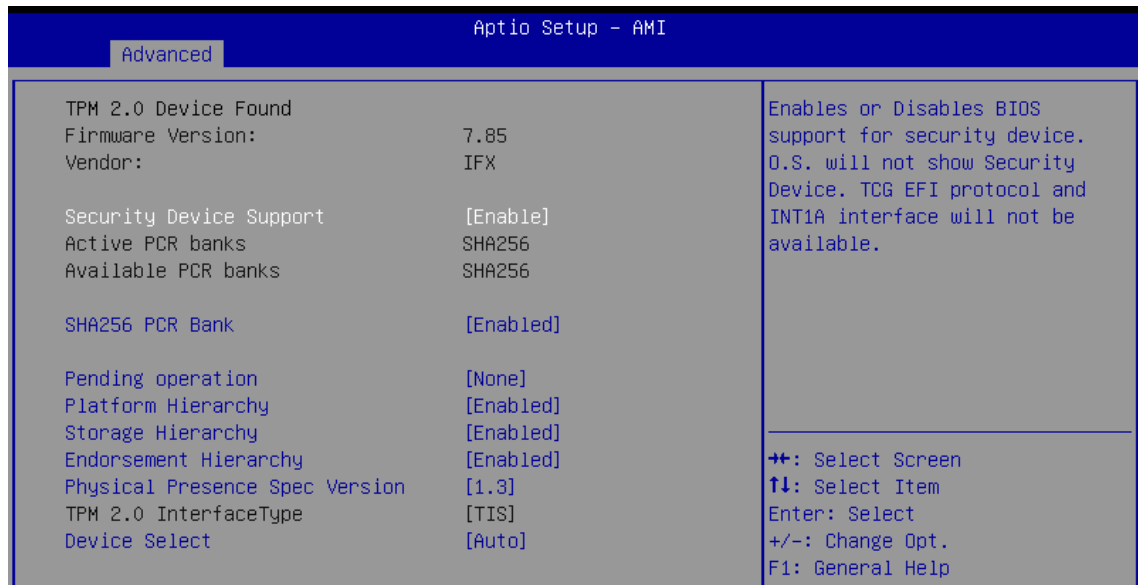

Figure 4 3-3: Trusted Computing

Control the TPM device status and display related information if TPM chip is present.

4.3.4 ACPI Settings

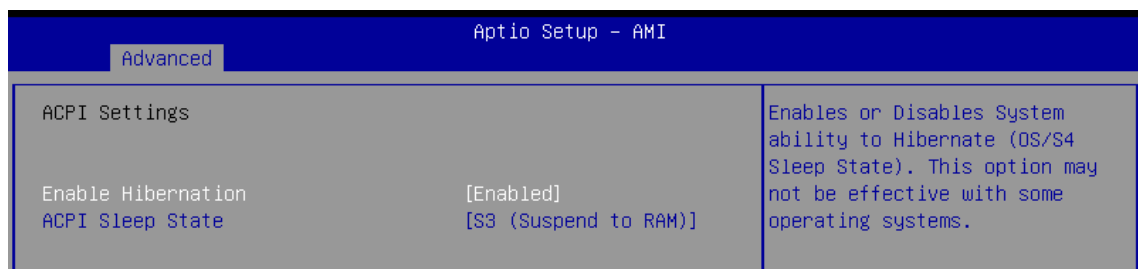

Figure 4 3-4: ACPI Settings

Enable Hibernation

Enables or Disables System ability to Hibernate (OS/S4 Sleep State). This option may not be effective with some operating systems.

ACPI Sleep State

Select the highest ACPI sleep state the system will enter when the SUSPEND button is pressed.

4.3.5 IT8786 Super IO Configuration

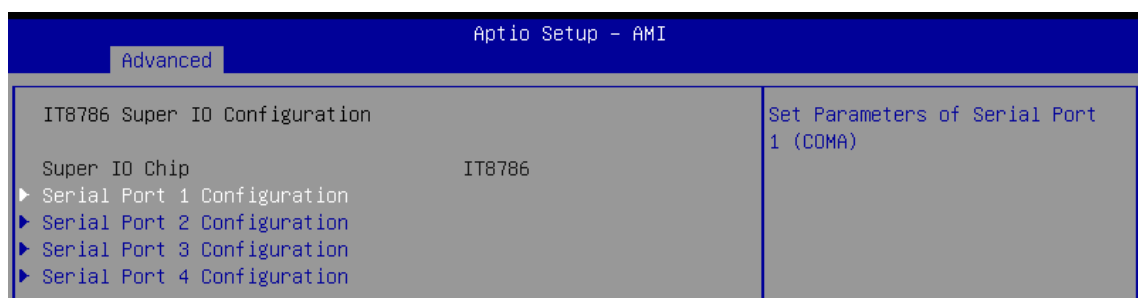

Figure 4 3-5: IT8786 Super IO Configuration

4.3.5.1 Serial Port X Configuration

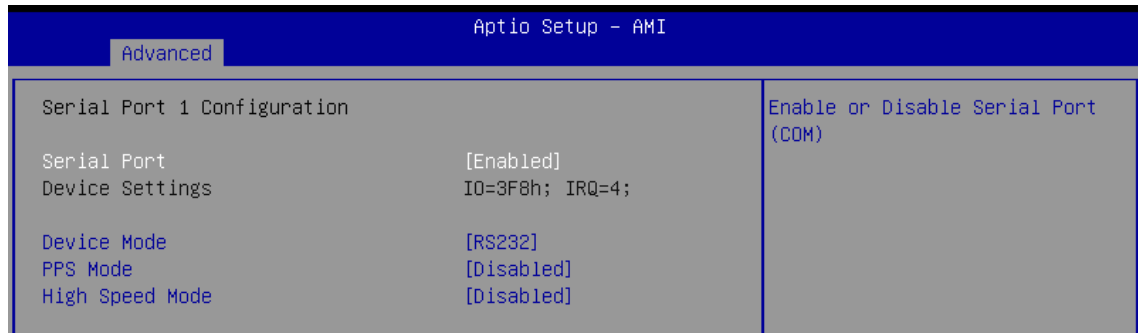

Figure 4-3-5-1: Serial Port X Configuration

Serial Port

Enable or Disable Serial Port (COM)

Device Mode

Select Device Mode.

PPS Mode

Enable or Disable PPS.

High Speed Mode

Enable or Disable Serial Port High Speed. (Serial Port 1 only)

4.3.6 Hardware Monitor

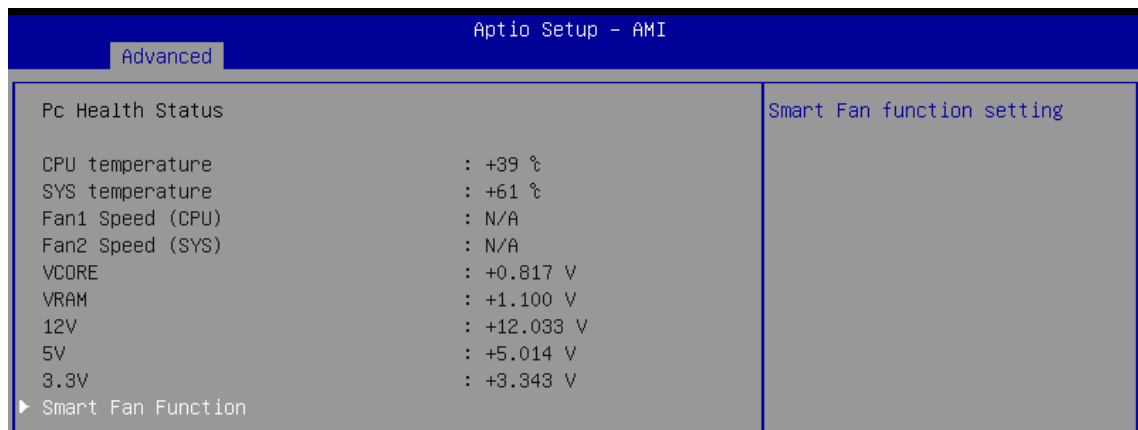

Figure 4-3-6: Hardware Monitor

The IT8786 SIO features an enhanced hardware monitor providing thermal, fan speed, and system voltages' status monitoring.

4.3.6.1 Smart Fan Function

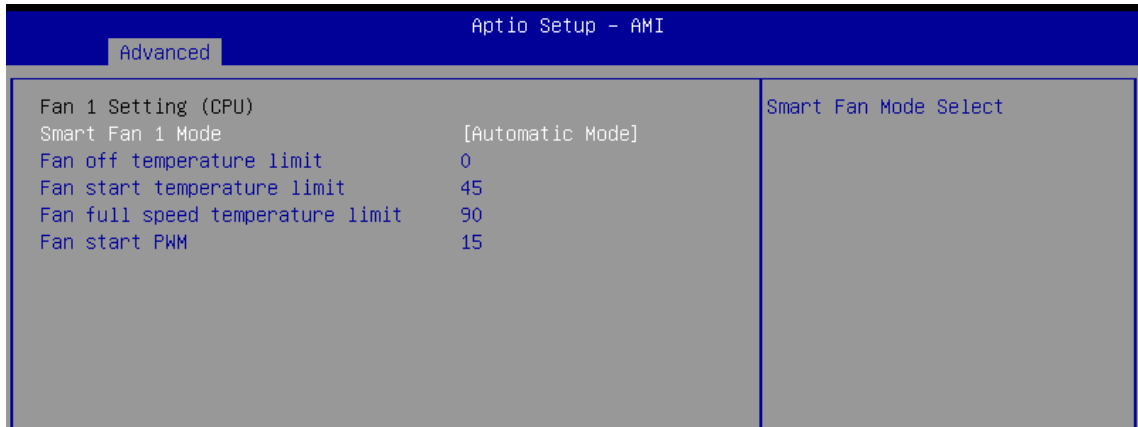

Figure 4-3-6-1: Smart Fan Function

Smart Fan X Mode

Smart Fan Mode Select.

Fan off temperature limit

Fan will off when temperature lower than this limit

Fan start temperature limit

Fan will work when temperature higher than this limit.

Fan full speed temperature limit

Fan will full speed when temperature higher than this limit

Fan start PWM

Fan will start with this PWM value.

Manual PWM Setting

Fan will work with this Manual PWM Value

4.3.7 Network Stack Configuration

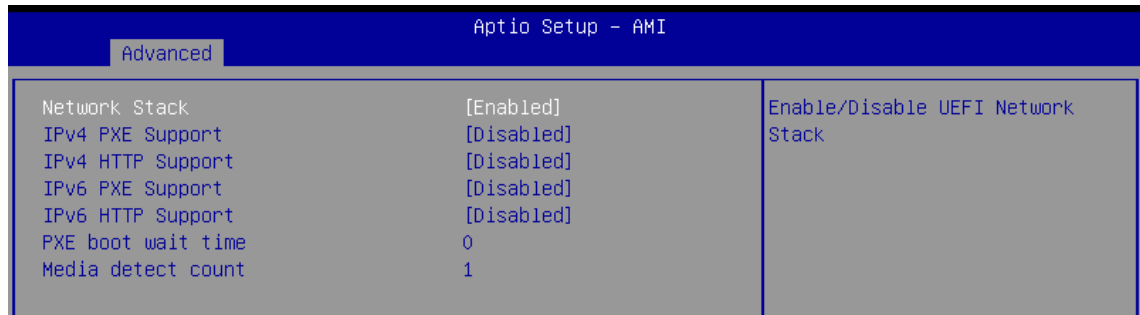

Figure 4-3-7: Network Stack Configuration

Network Stack

Enable/Disable UEFI Network Stack.

IPv4 PXE Support

Enable/Disable IPv4 PXE boot support. If disabled, IPv4 PXE boot support will not be available.

IPv4 HTTP Support

Enable/Disable IPv4 HTTP boot support. If disabled, IPv4 HTTP boot support will not be available.

IPv6 PXE Support

Enable/Disable IPv6 PXE boot support. If disabled, IPv6 PXE boot support will not be available.

IPv6 HTTP Support

Enable/Disable IPv6 HTTP boot support. If disabled, IPv6 HTTP boot support will not be available.

PXE boot wait time

Wait time in seconds to press ESC key to abort the PXE boot. Use either +/- or numeric keys to set the value.

Media detect count

Number of times the presence of media will be checked. Use either +/- or numeric keys to set the value.

4.3.8 NVMe Configuration

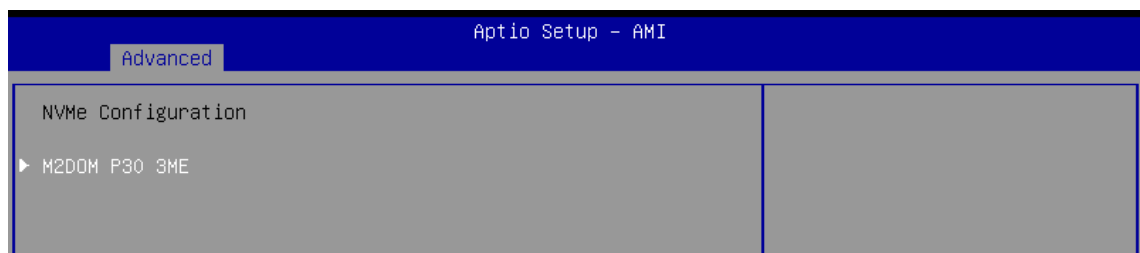

Figure 4-3-8: NVMe Configuration

Display NVMe controller and Drive information.

4.4 Chipset Function

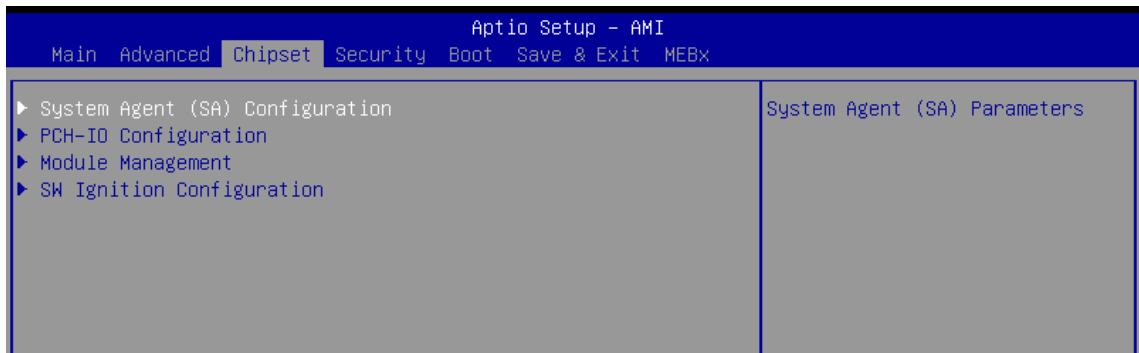

Figure 4-4: BIOS Chipset Menu

Select Chipset tab to enter chipset BIOS setup options, such as System Agent (SA) Configuration, PCH-IO Configuration, and SW Ignition Configuration.

4.4.1 System Agent (SA) Configuration

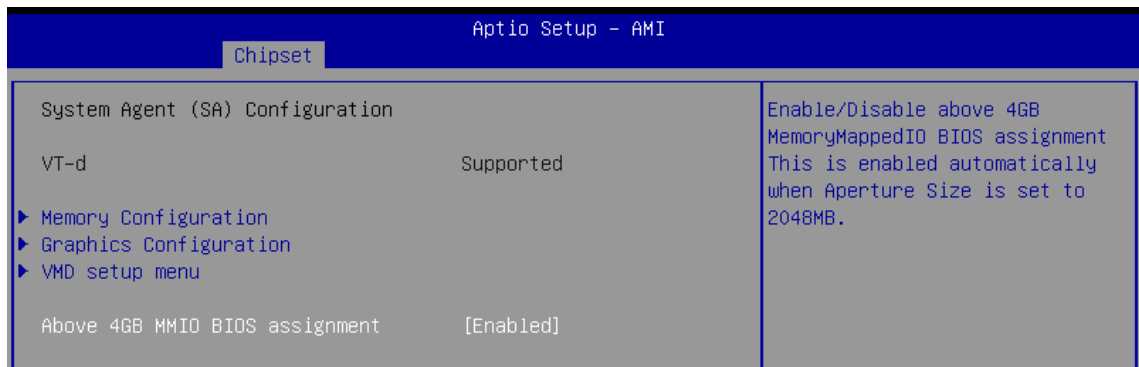

Figure 4-4-1: System Agent (SA) Configuration

Above 4GB MMIO BIOS assignment

Enable/Disable above 4GB MemoryMappedIO BIOS assignment

This is enabled automatically when Aperture Size is set to 2048MB.

4.4.1.1 Memory Configuration

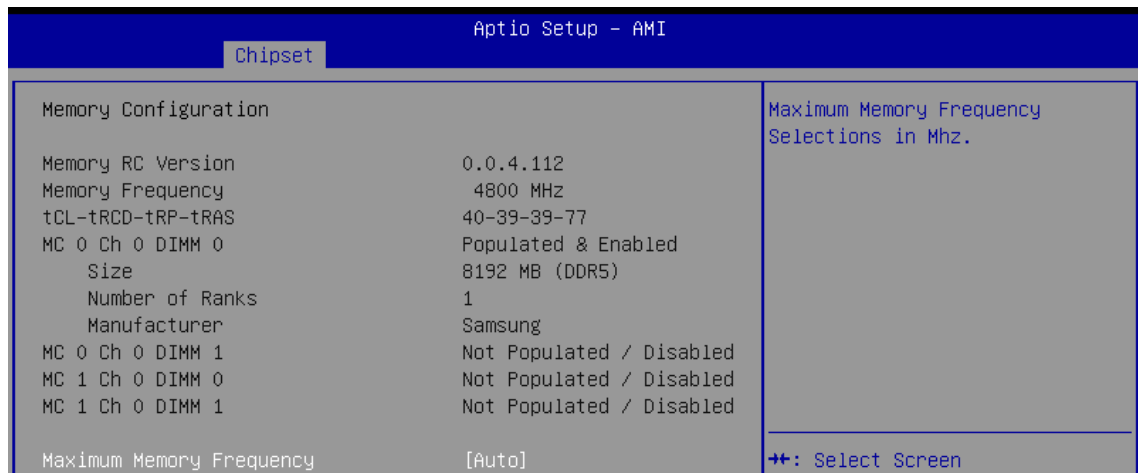

The screenshot shows the 'Memory Configuration' section of the Aptio Setup - AMI BIOS. The 'Chipset' tab is selected. The configuration includes:

Memory Configuration	Value	Maximum Memory Frequency Selections in Mhz.
Memory RC Version	0.0.4.112	
Memory Frequency	4800 MHz	
tCL-tRCD-tRP-tRAS	40-39-39-77	
MC 0 Ch 0 DIMM 0	Populated & Enabled	
Size	8192 MB (DDR5)	
Number of Ranks	1	
Manufacturer	Samsung	
MC 0 Ch 0 DIMM 1	Not Populated / Disabled	
MC 1 Ch 0 DIMM 0	Not Populated / Disabled	
MC 1 Ch 0 DIMM 1	Not Populated / Disabled	
Maximum Memory Frequency	[Auto]	++: Select Screen

Figure 4-4-1-1: Memory Configuration

Maximum Memory Frequency

Maximum Memory Frequency Selections in Mhz.

4.4.1.2 Graphics Configuration

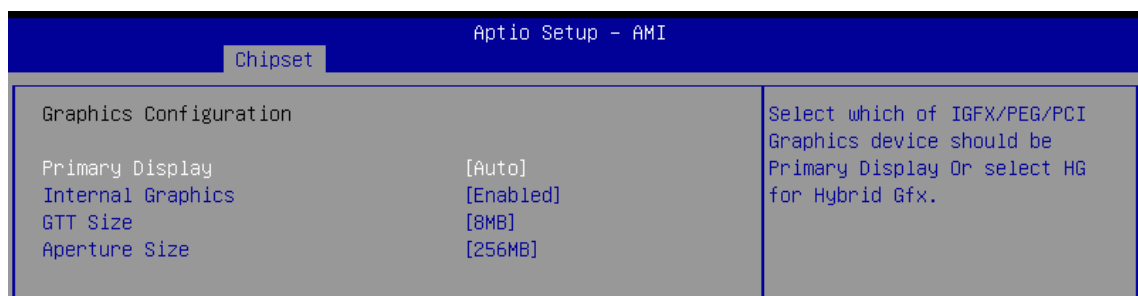

The screenshot shows the 'Graphics Configuration' section of the Aptio Setup - AMI BIOS. The 'Chipset' tab is selected. The configuration includes:

Graphics Configuration	Value	Select which of IGFX/PEG/PCI Graphics device should be Primary Display Or select HG for Hybrid Gfx.
Primary Display	[Auto]	
Internal Graphics	[Enabled]	
GTT Size	[8MB]	
Aperture Size	[256MB]	

Figure 4-4-1-2: Graphics Configuration

Primary Display

Select which of IGFX/PEG/PCI Graphics device should be Primary Display Or select HG for Hybrid Gfx.

Internal Graphics

Keep IGFX enabled based on the setup options.

GTT Size

Select the GTT Size.

Aperture Size

Select the Aperture Size

Note : Above 4GB MMIO BIOS assignment is automatically enabled when selecting > 2048MB aperture. To use this feature, please disable CSM Support.

4.4.1.3 VMD setup menu



Figure 4-4-1-3: VMD setup menu

Enable VMD controller

Enable/Disable to VMD controller.

4.4.2 PCH-IO Configuration

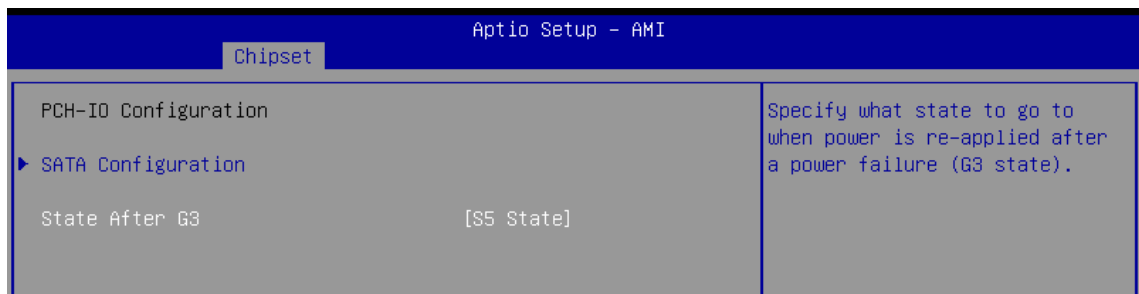

Figure 4-4-2: PCH-IO Configuration

State After G3

Specify what state to go to when power is re-applied after a power failure (G3 state).

4.4.2.1 SATA Configuration

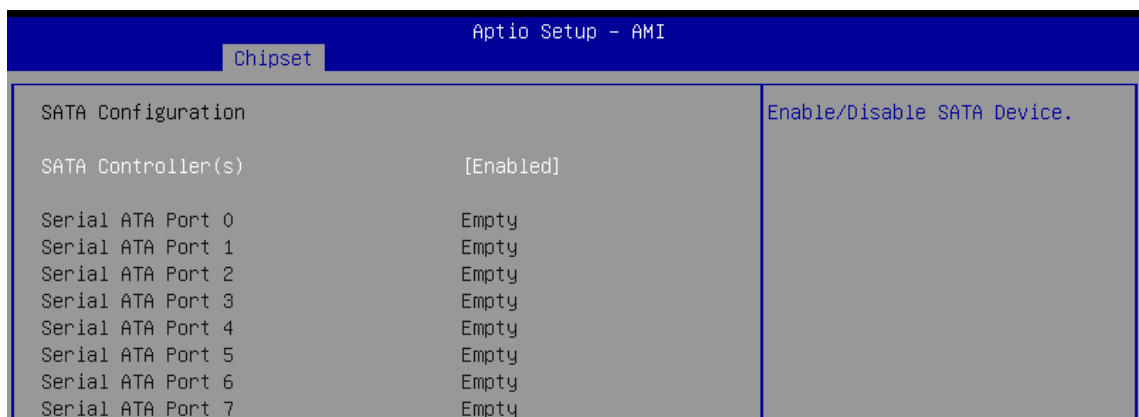

Figure 4-4-2-1: SATA Configuration

SATA Controller(s)

Enable/Disable SATA Device.

4.4.3 Module Management

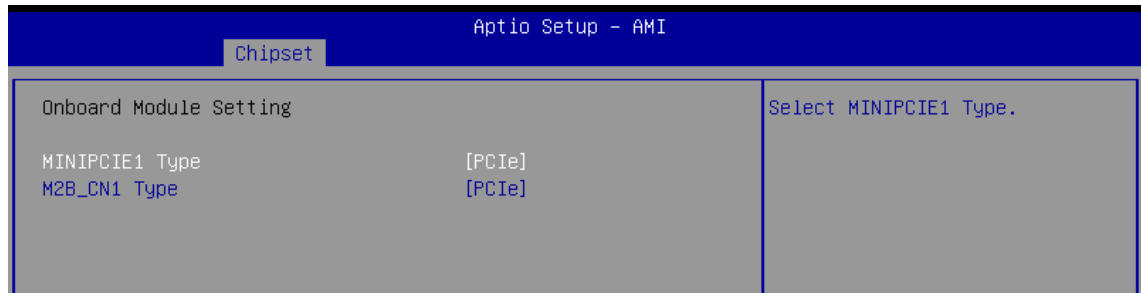

Figure 4-4-3: Module Management

MINIPCI1 Type

Select MINIPCI1 Type.

M2B_CN1 Type

Select M2B_CN1 Type.

4.4.4 SW Ignition Configuration

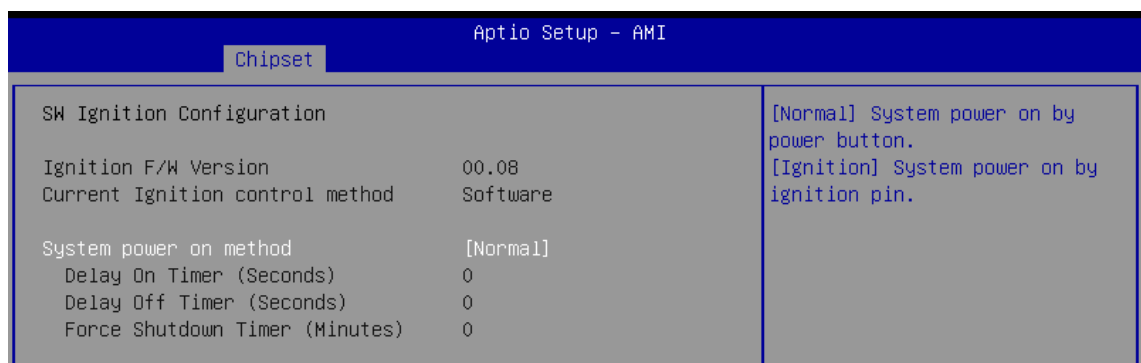

Figure 4-4-4: SW Ignition Configuration

System power on method

[Normal] System power on by power button.

[Ignition] System power on by ignition pin.

Delay On Timer (Seconds)

The delay time after user trigger ignition on signal (Seconds).

Delay Off Timer (Seconds)

The delay time after user trigger ignition off signal (Seconds).

Force Shutdown Timer (Minutes)

Used to force cut off system power when OS unable gracefully shutdown system successfully.

4.5 Security Function

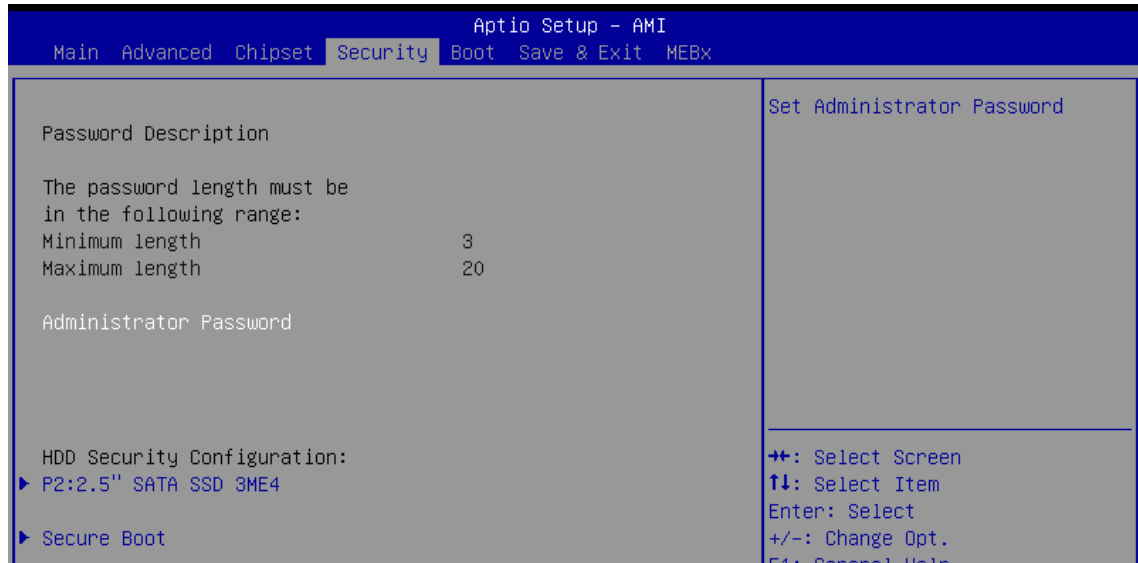

Figure 4-5: BIOS Security Menu

Administrator Password

Set Administrator Password

4.5.1 HDD Security Configuration

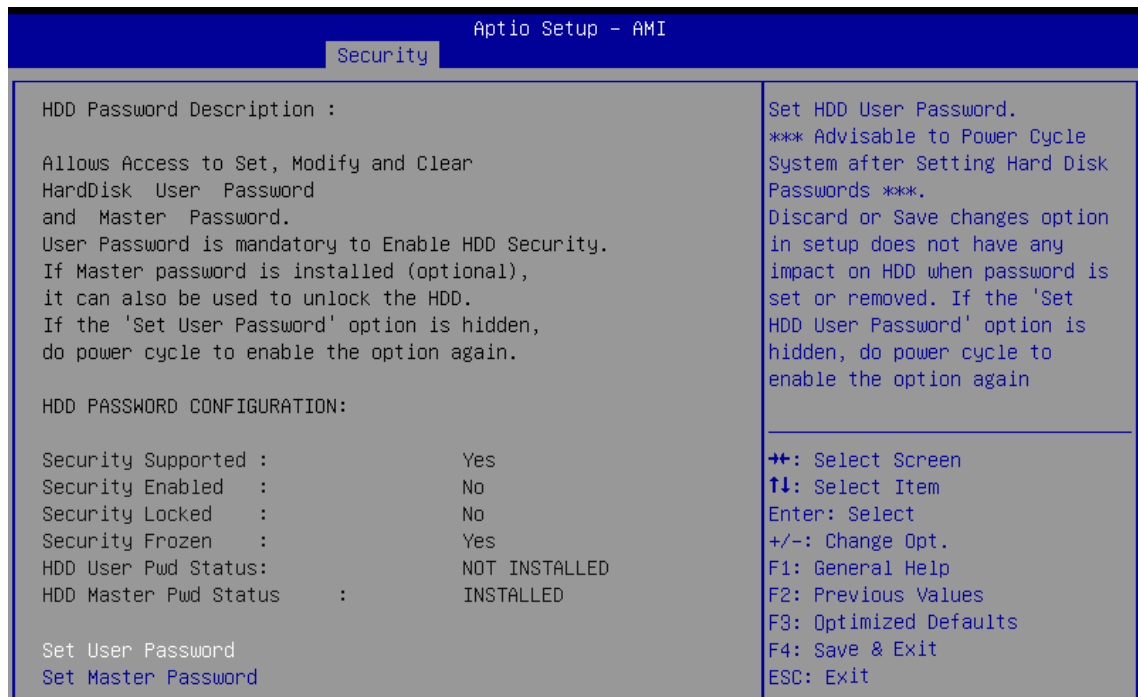

Figure 4-5-1: HDD Security Configuration

Set User Password

Set HDD User Password.

*** Advisable to Power Cycle System after Setting Hard Disk Passwords ***.

Discard or Save changes option in setup does not have any impact on HDD when password is set or removed. If the 'Set HDD User Password' option is hidden, do power cycle to enable the option again.

Set Master Password

Set Master Password.

4.5.2 Secure Boot

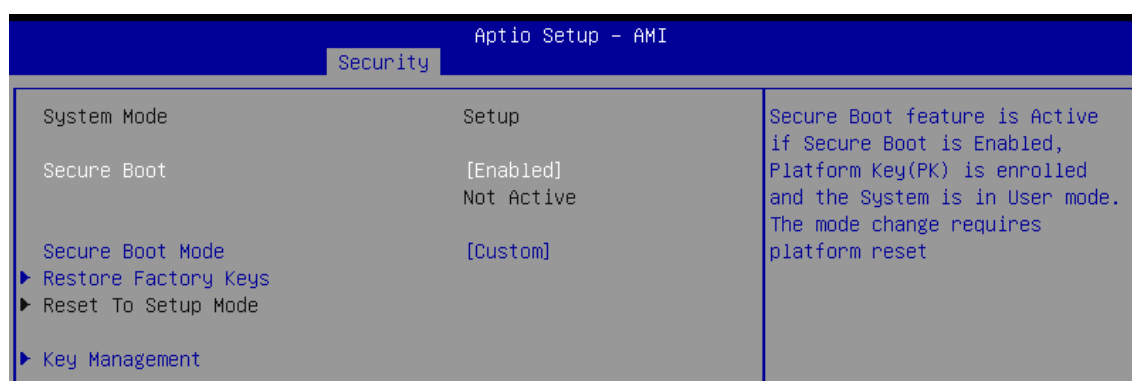

Figure 4-5-2: Secure Boot

Secure Boot

Secure Boot feature is Active if Secure Boot is Enabled, Platform Key(PK) is enrolled and the System is in User mode.

The mode change requires platform reset.

Secure Boot Mode

Secure Boot mode options:

Standard or Custom.

In Custom mode, Secure Boot Policy variables can be configured by a physically present user without full authentication.

Restore Factory Keys

Force System to User Mode.

Install factory default Secure Boot key databases.

Reset To Setup Mode

Delete all Secure Boot key databases from NVRAM.

Key Management

Enables expert users to modify Secure Boot Policy variables without variable authentication.

4.6 Boot Function

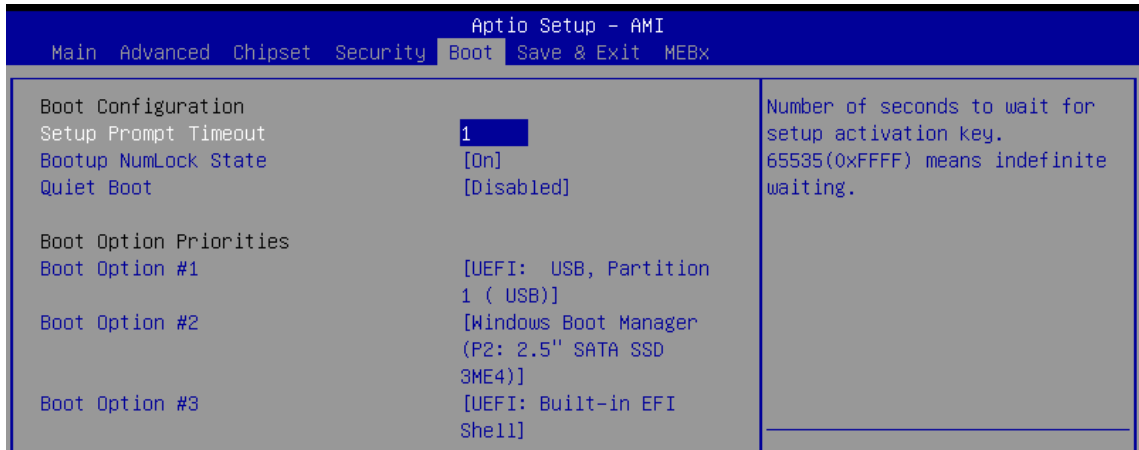

Figure 4-6: BIOS Boot Menu

Setup Prompt Timeout

Number of seconds to wait for setup activation key. 65535(0xFFFF) means indefinite waiting.

Bootup NumLock State

Select the keyboard NumLock state

Quiet Boot

Enables or disables Quiet Boot option

Boot Option Priorities

Sets the system boot order

4.7 Save & Exit

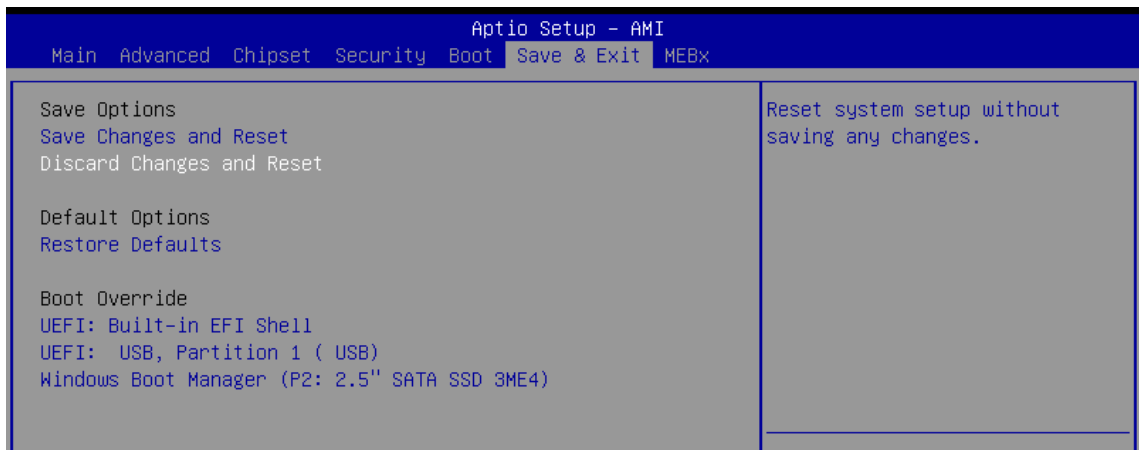

Figure 4-7: BIOS Save & Exit Menu

Save Changes and Reset

Reset the system after saving the changes.

Discard Changes and Reset

Reset system setup without saving any changes.

Default Options

Restore/Load Default values for all the setup options.

A

APPENDIX A : Isolated DIO Guide

A.1 Function Description

The IVX-1000 offers a 16-bit Non-Isolated DIO /two 16-bit Isolated DIO 20-pin terminal block connector, a watchdog timer, and a 4-port POE.

Isolated DIO pins are fix by Hardware design that cannot change in/out direction in runtime process.

DIO definition is shown below :

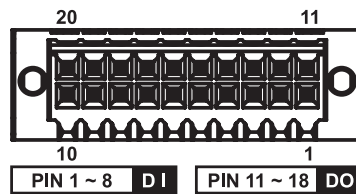

Pin No.	Isolated DIO Definition	Non-Isolated DIO Definition	Pin No.	Isolated DIO Definition	Non-Isolated DIO Definition
1	DI 0	DIO 0	11	DO 0	DIO 8
2	DI 1	DIO 1	12	DO 1	DIO 9
3	DI 2	DIO 2	13	DO 2	DIO 10
4	DI 3	DIO 3	14	DO 3	DIO 11
5	DI 4	DIO 4	15	DO 4	DIO 12
6	DI 5	DIO 5	16	DO 5	DIO 13
7	DI 6	DIO 6	17	DO 6	DIO 14
8	DI 7	DIO 7	18	DO 7	DIO 15
9	DI COM	NC	19	DIO_GND	DIO_GND
10	DIO_GND	DIO_GND	20	External VDC	NC

POE definition is shown below :

Port No.	Definition	Port No.	Definition
1	POE 0	3	POE 2
2	POE 1	4	POE 3

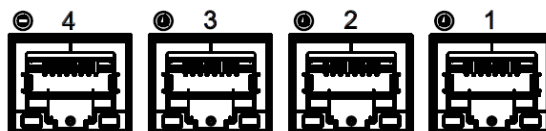

A.2 Isolated DIO Signal Circuit

DI Reference Circuit :

Sink Mode (NPN)

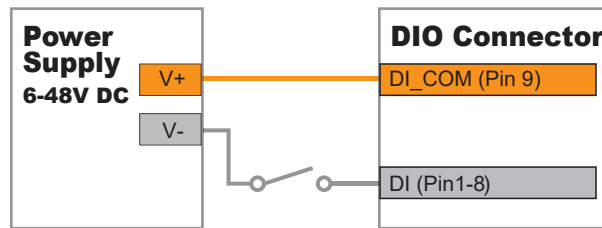

Source Mode (PNP)

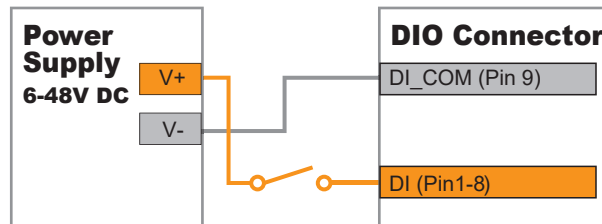

DO Reference Circuit :

Sink Mode
(NPN, Default)

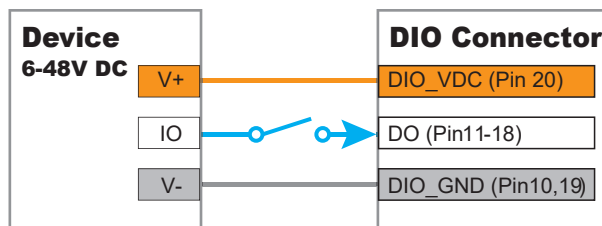

Source Mode
(PNP)

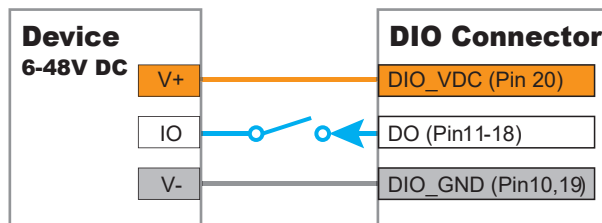

A.3 Isolated DIO Signal Circuit

Distribution folders include x32 and x64 versions, use the batch file for driver installation.

There are included as followed :

Win10_32.bat, and Win10_64.bat :

Installation for driver, and

Uninstall_32.bat, and Uninstall_64.bat :

Uninstallation for driver

Run batch file as Administrator.









Make sure Windows version before installation.

Header folders include head file for software developer or System Integration.

Manual folders include API description.

Sample folders include sample program, driver library, and API library for Windows/Linux

Source folders include sample program source code that compile on Visual Studio 2008/ubuntu16.04.

-  Distribution
-  Header
-  Manual
-  Sample
-  Source
-  Uninstall_32.bat
-  Uninstall_64.bat
-  Win10_32.bat
-  Win10_64.bat

A.3.1

Select the appropriate installation version (here is win10 64bit for example)

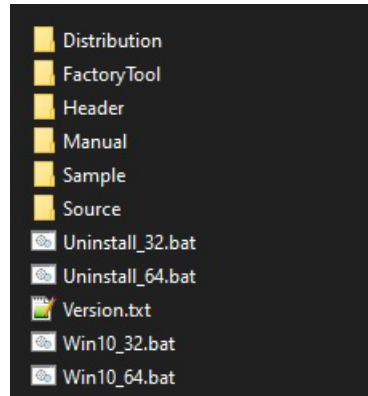

A.3.2 install process

UAC screen, please select Yes.

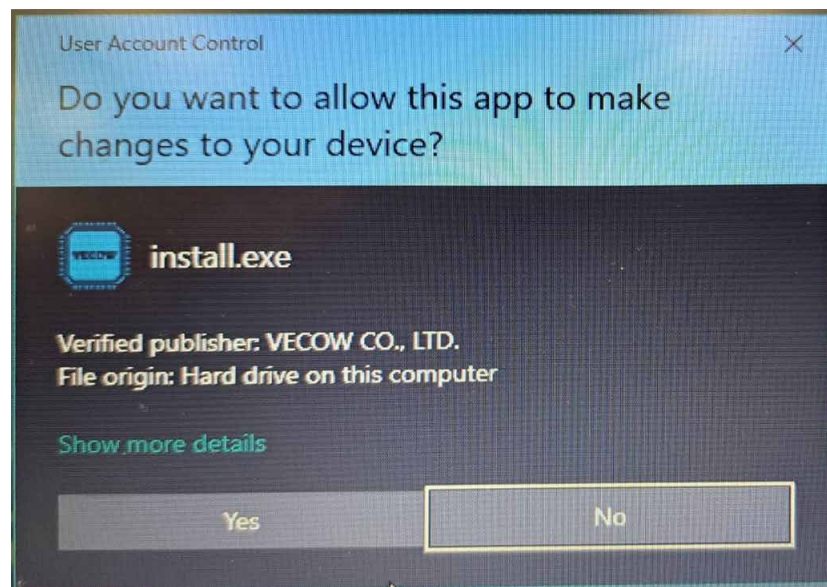

Install message

```
C:\windows\system32\cmd.exe
Install for Driver...
_
```

Install driver success.

```
C:\windows\system32\cmd.exe
Install for Driver...
Press any key to continue . . . . _
```

Install driver fail.

```
C:\windows\system32\cmd.exe
Install for Driver...
Access is denied.
Press any key to continue . . . . _
```

A.4 Sample

Execute demo tool.

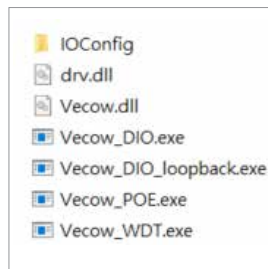

Windows

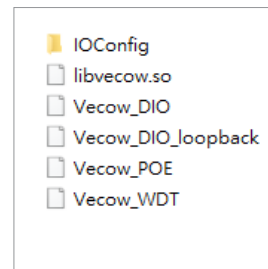

Linux

A.4.1 DIO Sample

A.4.1.1 Auto load SIO configuration(.\IOConfig\ machine series) and initial SIO then choosing IO port you want to control.

```
DIO sample version : v1.0.0609.0608
Load Vecow.dll at least v1.8.1409.0608
Vecow.dll Version : v1.8.1409.0608
Config : IO port I - Isolated DIO
         IO port II - Non-Isolated DIO(GPIO)

Choose IO : (1/2)
```

A.4.1.2 Select IO port mode(see Config).

```
C:\Users\van\Desktop\sample_08.1018\x64\Vecow_DIO.exe
DIO sample version : v1.0.0208.1018
Load Vecow.dll at least v1.0.1008.0812
Vecow.dll Version : v1.3.5008.1008
Config : IO port I - Isolated DIO
         IO port II - Isolated DIO

Initial SIO success!
Choose IO : (1/2) 2
Get initial IO config success!
Select Non-Isolated/Isolated mode : (0/1)
```

A.4.1.2.1 Isolated DIO access then choose DI or DO access.

```
C:\Users\van\Desktop\sample_08.1018\x64\Vecow_DIO.exe
DIO sample version : v1.0.0208.1018
Load Vecow.dll at least v1.0.1008.0812
Vecow.dll Version : v1.3.5008.1008
Config : IO port I - Isolated DIO
         IO port II - Isolated DIO

Initial SIO success!
Choose IO : (1/2) 2
Get initial IO config success!
Select Non-Isolated/Isolated mode : (0/1) 1

Isolated DIO access
Choose DI/DO : (0/1)
```

Figure. Isolated DIO access.

Step 1 DI access and set DI mode(sink or source).

```
C:\Users\van\Desktop\sample_08.1018\x64\Vecow_DIO.exe
DIO sample version : v1.0.0208.1018
Load Vecow.dll at least v1.0.1008.0812
Vecow.dll Version : v1.3.5008.1008
Config : IO port I - Isolated DIO
         IO port II - Isolated DIO

Initial SIO success!
Choose IO : (1/2) 2
Get initial IO config success!
Select Non-Isolated/Isolated mode : (0/1) 1

Isolated DIO access
Choose DI/DO : (0/1) 0
Setlect Sink/Source mode : (0/1)
```

Figure. Get DI sink/source mode data

```
C:\Users\van\Desktop\sample_08.1018\x64\Vecow_DIO.exe
DIO sample version : v1.0.0208.1018
Load Vecow.dll at least v1.0.1008.0812
Vecow.dll Version : v1.3.5008.1008
Config : IO port I - Isolated DIO
         IO port II - Isolated DIO

Initial SIO success!
Choose IO : (1/2) 2
Get initial IO config success!
Select Non-Isolated/Isolated mode : (0/1) 1

Isolated DIO access
Choose DI/DO : (0/1) 0
Setlect Sink/Source mode : (0/1) 0
Set DIO config success!
Get DI & DO data success!
Get DI2 data = 00
Press any key to continue . . .
```

Figure. DI sink mode data.

```
E:\sample_08.1018\x64\Vecow_DIO.exe
DIO sample version : v1.0.0208.1018
Load Vecow.dll at least v1.0.1008.0812
Vecow.dll Version : v1.3.5008.1008
Config : IO port I - Isolated DIO
         IO port II - Isolated DIO

Initial SIO success!
Choose IO : (1/2) 2
Get initial IO config success!
Select Non-Isolated/Isolated mode : (0/1) 1

Isolated DIO access
Choose DI/DO : (0/1) 0
Setlect Sink/Source mode : (0/1) 1
Set DIO config success!
Get DI & DO data success!
Get DI2 data = FF
Press any key to continue . . .
```

Figure. DI source mode data.

Step 2 DO access and set DO mode (sink or source).

```
E:\sample_08.1018\x64\Vecow_DIO.exe
DIO sample version : v1.0.0208.1018
Load Vecow.dll at least v1.0.1008.0812
Vecow.dll Version : v1.3.5008.1008
Config : IO port I - Isolated DIO
         IO port II - Isolated DIO

Initial SIO success!
Choose IO : (1/2) 2
Get initial IO config success!
Select Non-Isolated/Isolated mode : (0/1) 1

Isolated DIO access
Choose DI/DO : (0/1) 1
Setlect Sink/Source mode : (0/1)
```

Figure. Get DI sink/source mode data

Step 2.1 Choose DO port.

```
E:\sample_08.1018\x64\Vecow_DIO.exe
DIO sample version : v1.0.0208.1018
Load Vecow.dll at least v1.0.1008.0812
Vecow.dll Version : v1.3.5008.1008
Config : IO port I - Isolated DIO
         IO port II - Isolated DIO

Initial SIO success!
Choose IO : (1/2) 2
Get initial IO config success!
Select Non-Isolated/Isolated mode : (0/1) 1

Isolated DIO access
Choose DI/DO : (0/1) 1
Setlect Sink/Source mode : (0/1) 0
Set DIO config success!
Get DI & DO data success!
Choose DO port : (1~8, 9 = All port)
```

Step 2.2 Set DO high or low then show message.

```
E:\sample_08.1018\x64\Vecow_DIO.exe
DIO sample version : v1.0.0208.1018
Load Vecow.dll at least v1.0.1008.0812
Vecow.dll Version : v1.3.5008.1008
Config : IO port I - Isolated DIO
         IO port II - Isolated DIO

Initial SIO success!
Choose IO : (1/2) 2
Get initial IO config success!
Select Non-Isolated/Isolated mode : (0/1) 1

Isolated DIO access
Choose DI/DO : (0/1) 1
Setlect Sink/Source mode : (0/1) 0
Set DIO config success!
Get DI & DO data success!
Choose DO port : (1~8, 9 = All port) 9
Set High/Low : (0/1)
```

A.4.1.2.2 GPIO access and set GPIO configuration.

```
C:\Users\van\Desktop\sample_08.1018\x64\Vecow_DIO.exe
DIO sample version : v1.0.0308.1108
Load Vecow.dll at least v1.0.1008.0812
Vecow.dll Version : v1.3.5008.1008
Config : IO port I - Isolated DIO
         IO port II - Non-Isolated DIO(GPIO)

Initial SIO success!
Choose IO : (1/2) 2
Get initial IO config success!
Select Non-Isolated/Isolated mode : (0/1) 0

GPIO access
Current GPIO config : 0xFF00
Set GPIO config In/Out(0/1) : 0x
```

Step 1 Example : Set GPIO configuration 0xFF00 and get GPIO data(loopback test).

```
C:\Users\van\Desktop\sample_08.1018\x64\Vecow_DIO.exe
DIO sample version : v1.0.0308.1108
Load Vecow.dll at least v1.0.1008.0812
Vecow.dll Version : v1.3.5008.1008
Config : IO port I - Isolated DIO
         IO port II - Non-Isolated DIO(GPIO)

Initial SIO success!
Choose IO : (1/2) 2
Get initial IO config success!
Select Non-Isolated/Isolated mode : (0/1) 0

GPIO access
Current GPIO config : 0xFF00
Set GPIO config In/Out(0/1) : 0xFF00
Set GPIO config success!
Get GPIO data success!
Current GPIO data : 0x1212
Set GPIO data : 0x
```

Step 2 Set GPIO data 0x4321 and get GPIO data(loopback test).

```
C:\Users\van\Desktop\sample_08.1018\x64\Vecow_DIO.exe
DIO sample version : v1.0.0308.1108
Load Vecow.dll at least v1.0.1008.0812
Vecow.dll Version : v1.3.5008.1008
Config : IO port I - Isolated DIO
         IO port II - Non-Isolated DIO(GPIO)

Initial SIO success!
Choose IO : (1/2) 2
Get initial IO config success!
Select Non-Isolated/Isolated mode : (0/1) 0

GPIO access
Current GPIO config : 0xFF00
Set GPIO config In/Out(0/1) : 0xFF00
Set GPIO config success!
Get GPIO data success!
Current GPIO data : 0x1212
Set GPIO data : 0x4321
Set GPIO data success!
GPIO data : 0x4343
Press any key to continue . . .
```

A.4.2 DIO Loopback Test

To use the Vecow_DIO_loopback function, a test fixture is required. For the detailed connection method of the test fixture, please refer to the relevant documents of vecow.

Step 1 Please select Vecow_DIO_loopback

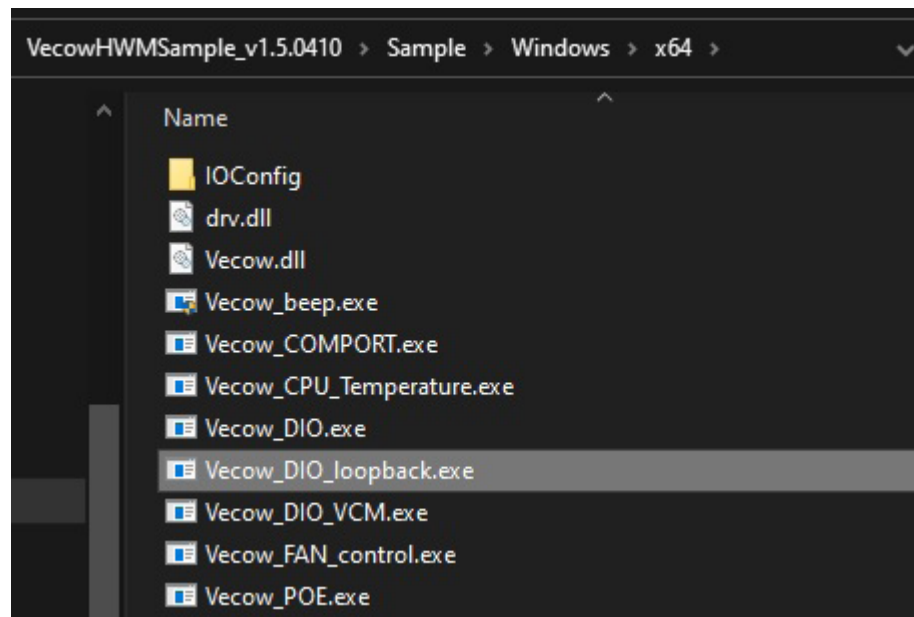

Step 2 Please select the mode to test

```
C:\Users\CFL1909\Desktop\VecowHWMSample_v1.5.0410\VecowHWMSample_v1.5.0410\S
DIO loopback sample version : v1.1.0406
Load Vecow.dll at least v1.9.0331
Vecow.dll Version : v1.26.0413.0000
PCB_ver = A
How many IO temp_port : (1/2) 1
Select Non-Isolated(GPIO)/Isolated mode : (0/1) 1
Setlect DO Sink(NPN)/Source mode(PNP) : (0/1) 0
```

Step 3 A normal test will continue to send data from DO, and DI will receive the same data and execute it repeatedly (the test will not stop).

```
C:\Users\CFL1909\Desktop\VecowHWMSample_v1.5.0410\VecowHWMSample_v1.5  
DI1 = 0x80  
DI check = 0x80  
  
DO = 0x81  
DI1 = 0x81  
DI check = 0x81  
  
DO = 0x82  
DI1 = 0x82  
DI check = 0x82  
  
DO = 0x83  
DI1 = 0x83  
DI check = 0x83  
  
DO = 0x84  
DI1 = 0x84  
DI check = 0x84  
  
DO = 0x85  
DI1 = 0x85  
DI check = 0x85  
  
DO = 0x86  
DI1 = 0x86  
DI check = 0x86  
  
DO = 0x87  
DI1 = 0x87
```

Step 4 When the test is wrong, it will stop the test after 6 consecutive tests and display an error message.

```
C:\Users\CFL1909\Desktop\VecowHWMSample_v1.5.041
Set DIO config success!
DO = 0x00
DI1 = 0xff
DI check = 0x00

DO = 0x01
DI1 = 0xff
DI check = 0x01

DO = 0x02
DI1 = 0xff
DI check = 0x02

DO = 0x03
DI1 = 0xff
DI check = 0x03

DO = 0x04
DI1 = 0xff
DI check = 0x04

DO = 0x05
DI1 = 0xff
DI check = 0x05

IO port 1 error 6 times
Sat Jun 18 00:36:24 2185
```

A.4.3 POE

Step 1 Initial POE and auto detected useful slave address ID.

```
Select C:\Users\van\Desktop\1111\Vecow_POE.exe
POE sample version : v1.0.1408.1112
Load Vecow.dll at least v1.0.1008.0812
Vecow.dll Version : v1.4.6108.1114

Initial POE success!
Usable slave address ID : 0
Select slave address ID :
```

Step 2 Choose useful slave address ID and show its address, then choose POE port that you want to control.

```
C:\Users\van\Desktop\1111\Vecow_POE.exe
POE sample version : v1.0.1408.1112
Load Vecow.dll at least v1.0.1008.0812
Vecow.dll Version : v1.4.6108.1114

Initial POE success!
Usable slave address ID : 0
Select slave address ID : 0
Salve address : 0x40
Choose POE port : (0~3, 4 = All port)
```

Step 3 Set Manual or Auto mode.

```
C:\Users\van\Desktop\1111\Vecow_POE.exe
POE sample version : v1.0.1408.1112
Load Vecow.dll at least v1.0.1008.0812
Vecow.dll Version : v1.4.6108.1114

Initial POE success!
Usable slave address ID : 0
Select slave address ID : 0
Salve address : 0x40
Choose POE port : (0~3, 4 = All port) 4
Set Manual/Auto mode : (0/1)
```

Step 3.1 Set Auto mode and show success message.

```
C:\Users\van\Desktop\1111\Vecow_POE.exe
POE sample version : v1.0.1408.1112
Load Vecow.dll at least v1.0.1008.0812
Vecow.dll Version : v1.4.6108.1114

Initial POE success!
Usable slave address ID : 0
Select slave address ID : 0
Salve address : 0x40
Choose POE port : (0~3, 4 = All port) 4
Set Manual/Auto mode : (0/1) 1
Set Auto mode success!
Press any key to continue . . .
```

Step 3.2 Set Manual mode and then turn OF/OFF POE port.

```
Select C:\Users\van\Desktop\1111\Vecow_POE.exe
POE sample version : v1.0.1408.1112
Load Vecow.dll at least v1.0.1008.0812
Vecow.dll Version : v1.4.6108.1114

Initial POE success!
Usable slave address ID : 0
Select slave address ID : 0
Salve address : 0x40
Choose POE port : (0~3, 4 = All port) 4
Set Manual/Auto mode : (0/1) 0
Set Manual mode success!
Set POE port OFF/ON : (0/1)
```

Step 3.3 Set POE port success message.

```
C:\Users\van\Desktop\1111\Vecow_POE.exe
POE sample version : v1.0.1408.1112
Load Vecow.dll at least v1.0.1008.0812
Vecow.dll Version : v1.4.6108.1114

Initial POE success!
Usable slave address ID : 0
Select slave address ID : 0
Salve address : 0x40
Choose POE port : (0~3, 4 = All port) 4
Set Manual/Auto mode : (0/1) 0
Set Manual mode success!
Set POE port OFF/ON : (0/1) 1
Set POE success!
Press any key to continue . . .
```

A.4.4 WDT

A.4.4.1 WDT once

Step 1 Auto load SIO configuration and initial SIO then set WDT seconds.

```
C:\Users\van\Desktop\sample_08.1018\x64\Vecow_WDT.exe
WDT sample version : v1.0.0208.1018
Load Vecow.dll at least v1.0.1008.0812
Vecow.dll Version : v1.3.5008.1008
Config : IO port I - Isolated DIO
         IO port II - Isolated DIO

Initial SIO success!
Get initial WDT success!
Set WDT timer seconds (1~3932100) :
```

Step 2 Set WDT success message.

```
C:\Users\van\Desktop\sample_08.1018\x64\Vecow_WDT.exe
WDT sample version : v1.0.0208.1018
Load Vecow.dll at least v1.0.1008.0812
Vecow.dll Version : v1.3.5008.1008
Config : IO port I - Isolated DIO
         IO port II - Isolated DIO

Initial SIO success!
Get initial WDT success!
Set WDT timer seconds (1~3932100) : 10
Set WDT success!
```

Step 3 Time out message.

```
C:\Users\van\Desktop\sample_08.1018\x64\Vecow_WDT.exe
WDT sample version : v1.0.0208.1018
Load Vecow.dll at least v1.0.1008.0812
Vecow.dll Version : v1.3.5008.1008
Config : IO port I - Isolated DIO
         IO port II - Isolated DIO

Initial SIO success!
Get initial WDT success!
Set WDT timer seconds (1~3932100) : 10
Set WDT success!
if reboot, WDT out early
if reboot, WDT out in range
if reboot, WDT out late
```

A.4.5 WDT LOOP

Step 1 Auto load SIO configuration and initial SIO then set WDT loop seconds.

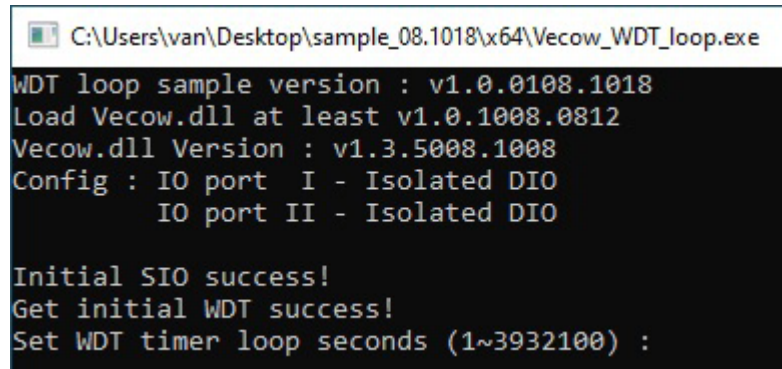

```
C:\Users\van\Desktop\sample_08.1018\x64\Vecow_WDT_loop.exe
WDT loop sample version : v1.0.0108.1018
Load Vecow.dll at least v1.0.1008.0812
Vecow.dll Version : v1.3.5008.1008
Config : IO port I - Isolated DIO
         IO port II - Isolated DIO

Initial SIO success!
Get initial WDT success!
Set WDT timer loop seconds (1~3932100) :
```

Step 2 80% WDT time will rest WDT again, if close .exe will reboot.

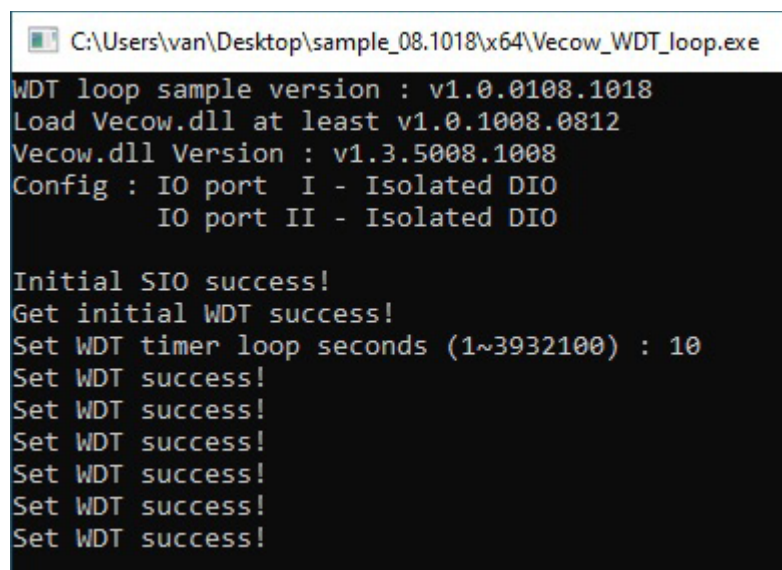

```
C:\Users\van\Desktop\sample_08.1018\x64\Vecow_WDT_loop.exe
WDT loop sample version : v1.0.0108.1018
Load Vecow.dll at least v1.0.1008.0812
Vecow.dll Version : v1.3.5008.1008
Config : IO port I - Isolated DIO
         IO port II - Isolated DIO

Initial SIO success!
Get initial WDT success!
Set WDT timer loop seconds (1~3932100) : 10
Set WDT success!
Set WDT success!
Set WDT success!
Set WDT success!
Set WDT success!
Set WDT success!
Set WDT success!
```

B

APPENDIX B : Software Functions

B.1 Driver API Guide

In Header folder, Vecow.h and VecowLinux.h contain usable API for Windows/Linux.

BOOL initial_SIO(BYTE Isolate_Type, BYTE DIO_NPN)

Initial machine for IO and watch dogtimer.

Isolate_Type : DIO type.

1 : Isolated DIO;

0 : Non-Isolated DIO(GPIO).

DIO_NPN : DI/DO type.

1 : PNP (Source) mode for European rule;

0 : NPN (Sink) mode for Japanese rule.

Return :

TRUE (1) : Success.

FALSE (0) : Fail (Driver not exists, or version is too old, or machine not match).

BOOL get_IO1_configuration(BYTE *Iso, BYTE *DI_mode, BYTE *DO_mode, WORD *Mask)

BOOL get_IO2_configuration(BYTE *Iso, BYTE *DI_mode, BYTE *DO_mode, WORD *Mask)

Get DIO configuration (by variable)

Isolate_Type : DIO type.

1 : Isolated DIO;

0 : Non-Isolated DIO (GPIO).

DI_mode ([7:0]) : DI type, pin setting by hexadecimal bitmask only for Isolated DIO.

0xFF : PNP (Source) mode for European rule;

0 : NPN (Sink) mode for Japanese rule.

DO_mode : DO type only for Isolated DIO.

1 : PNP (Source) mode for European rule;

0 : NPN (Sink) mode for Japanese rule.

Mask ([15:0]) : In/Out, pin setting by hexadecimal bitmask only for Non-Isolated DIO(GPIO).

1 : Output;

0 : Input

Return :

TRUE (1) : Success.

FALSE (0) : Fail (Initial error, or call by pointer error, or hardware problem).

BOOL set_IO1_configuration(BYTE Iso, BYTE DI_mode, BYTE DO_mode, WORD Mask)

BOOL set_IO2_configuration(BYTE Iso, BYTE DI_mode, BYTE DO_mode, WORD Mask)

Set DIO configuration.

Isolate_Type : DIO type.

1 : Isolated DIO;

0 : Non-Isolated DIO(GPIO).

DI_mode ([7:0]) : DI type, pin setting by hexadecimal bitmask only for Isolated DIO.

0xFF : PNP (Source) mode for European rule;

0 : NPN (Sink) mode for Japanese rule.

DO_mode : DO type only for Isolated DIO.

1 : PNP (Source) mode for European rule;

0 : NPN (Sink) mode for Japanese rule.

Mask ([15:0]) : In/Out, pin setting by hexadecimal bitmask only for Non-Isolated DIO(GPIO).

1 : Output;

0 : Input

Return :

TRUE (1) : Success.

FALSE (0) : Fail (Initial error or hardware problem).

BOOL get_DIO1(BYTE *DO_data, BYTE *DI_data)

BOOL get_DIO2(BYTE *DO_data, BYTE *DI_data)

Get isolated DIO output(DO) and input (DI).

DI ([7:0]) : Input state, pin setting by hexadecimal bitmask.

1 : High;

0 : Low.

DO ([7:0]) : Output state, pin setting by hexadecimal bitmask.

1 : High;

0 : Low.

Return :

TRUE (1) : Success.

FALSE (0) : Fail (Initial error or hardware problem).

FALSE (0) : Fail (Initial error or hardware problem).

BOOL set_DIO1(BYTE DO_data)

BOOL set_DIO2(BYTE DO_data)

Set isolated DIO output(DO).

DO ([7:0]) : Output state, pin setting by hexadecimal bitmask.

1 : High;

0 : Low.

Return :

TRUE (1) : Success.

FALSE (0) : Fail (Initial error or hardware problem).

FALSE (0) : Fail (Initial error or hardware problem).

BOOL get_GPIO1(WORD *GPIO_data)

Get GPIO.

GPIO_data ([15:0]) : GPIO state, pin setting by hexadecimal bitmask.
1 : High;
0 : Low.

Return :

TRUE (1) : Success.
FALSE (0) : Fail (Initial error or hardware problem).

BOOL set_GPIO1(WORD GPIO_data)

Set GPIO.

GPIO_data ([15:0]) : GPIO state, pin setting by hexadecimal bitmask.
1 : High;
0 : Low.

Return :

TRUE (1) : Success.
FALSE (0) : Fail (Initial error or hardware problem).

BOOL get_WDT(DWORD *WDT)

Get watchdog timer setup.

WDT : watchdog timer setup.

Unit : second (Range : 0 ~ 65535 sec, 1093 ~ 65535 min (=65580 ~ 3932100 sec)).

Return :

TRUE (1) : Success.
FALSE (0) : Fail (Initial error, or call by pointer error, or hardware problem).

BOOL set_WDT(DWORD WDT)

Set watchdog timer setup.

WDT : watchdog timer setup.

Unit : second (Range : 0 ~ 65535 sec, 1093 ~ 65535 min (=65580 ~ 3932100 sec)).

Return :

TRUE (1) : Success.
FALSE (0) : Fail (Initial error, or setup 0, or hardware problem).

BOOL cancel_WDT()

Cancel watchdog timer.

Return :

TRUE (1) : Success.
FALSE (0) : Fail (Initial error or hardware problem).

BOOL initial_POE(BYTE Scan, BYTE ID)

Initial POE.

Scan : POEID scan type

2 : Auto scan;

1 : Manual setup.

ID : POE ID by manual setting.

Range : 0~15.

Return :

TRUE (1) : Success.

FALSE (0) : Fail (Driver not exists, or version is too old, or out of range error).

BOOL get_POE_configuration(BYTE ID, BYTE *Auto, BYTE *Mask)

Get POE configuration (by variable).

ID : POE ID.

Range : 0~15.

Auto ([3:0]) : Auto mode, pin setting by hexadecimal bitmask.

1 : Auto;

0 : Manual.

Mask ([3:0]) : DC Enable/Disable, pin setting by hexadecimal bitmask.

1 : Enable;

0 : Disable.

Return :

TRUE (1) : Success.

FALSE (0) : Fail (Initial error, or out of range error, or call by pointer error, or hardware problem)

BOOL set_POE_configuration(BYTE ID, BYTE Auto, BYTE Mask)

Set POE configuration (by variable).

ID : POE ID.

Range : 0~15.

Auto ([3:0]) : Auto mode, pin setting by hexadecimal bitmask.

1 : Auto;

0 : Manual.

Mask ([3:0]) : DC Enable/Disable, pin setting by hexadecimal bitmask.

1 : Enable;

0 : Disable.

Return :

TRUE (1) : Success.

FALSE (0) : Fail (Initial error, or out of range error, or hardware problem).

BOOL get_POE(BYTE ID, BYTE *POE)

Get POE state.

ID : POE ID.

Range : 0~15.

POE ([3:0]) : POE state, pin setting by hexadecimal bitmask.

1 : On;

0 : Off.

Return :

TRUE (1) : Success.

FALSE (0) : Fail (Initial error, or out of range error, or call by pointer error, or hardware problem).

BOOL set_POE(BYTE ID, BYTE POE)

Set POE state.

A. ID : POE ID.

Range : 0~15.

B. POE ([3:0]) : POE state, pin setting by hexadecimal bitmask.

1 : On;

0 : Off.

Return :

TRUE (1) : Success.

FALSE (0) : Fail (Initial error, or out of range error, or hardware problem).

C

APPENDIX C : RAID Functions

C.1.1 SATA Mode for RAID

Please select SATA Device to RAID mode on BIOS menu.

Chipset → PCH-IO Configuration → SATA And RST Configuration → SATA Mode Selection → Intel RST Premium → Save Changes and Reset.

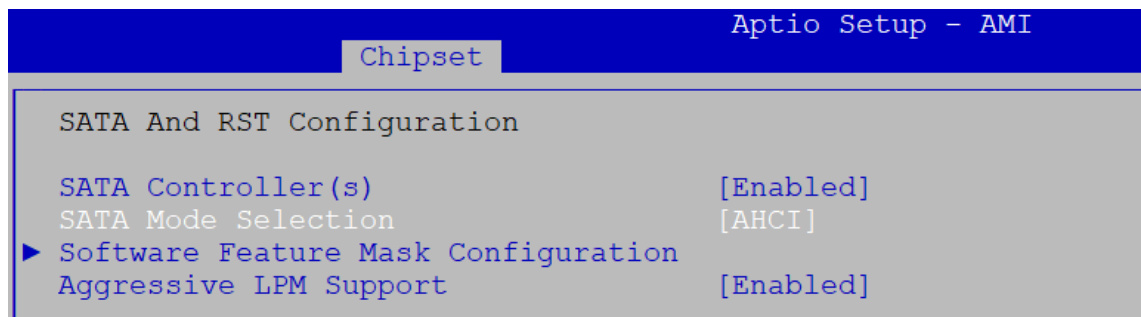

C.1.2 UEFI Mode for RAID

1. Into BIOS menu again, select Intel(R) Rapid Storage Technology on BIOS menu.

Advanced → Intel(R) Rapid Storage Technology

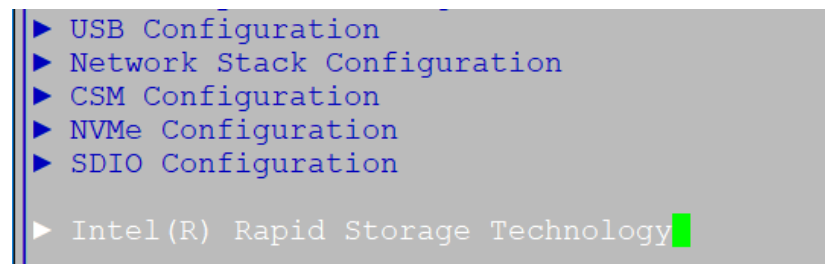

2. Select Create RAID Volume on BIOS menu.

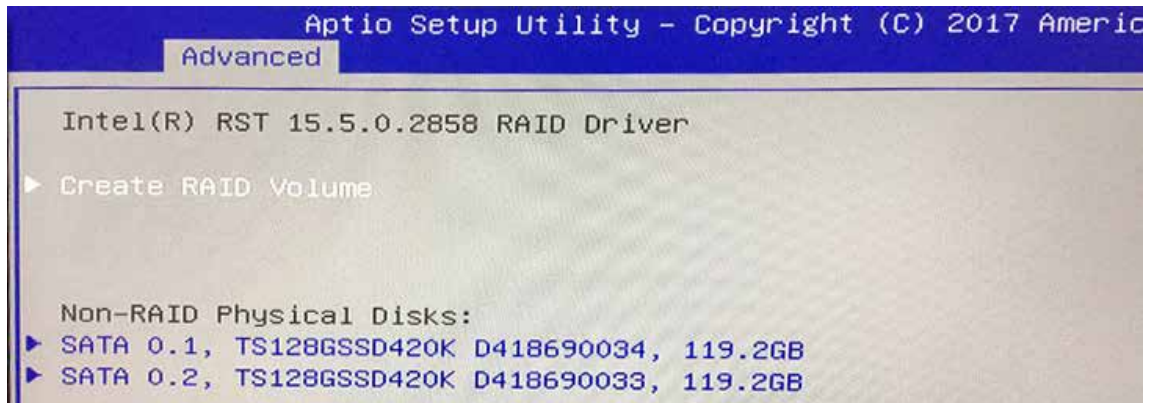

3. Select disks to create RAID Volume then Save Changes and Reset to install OS with EFI mode.

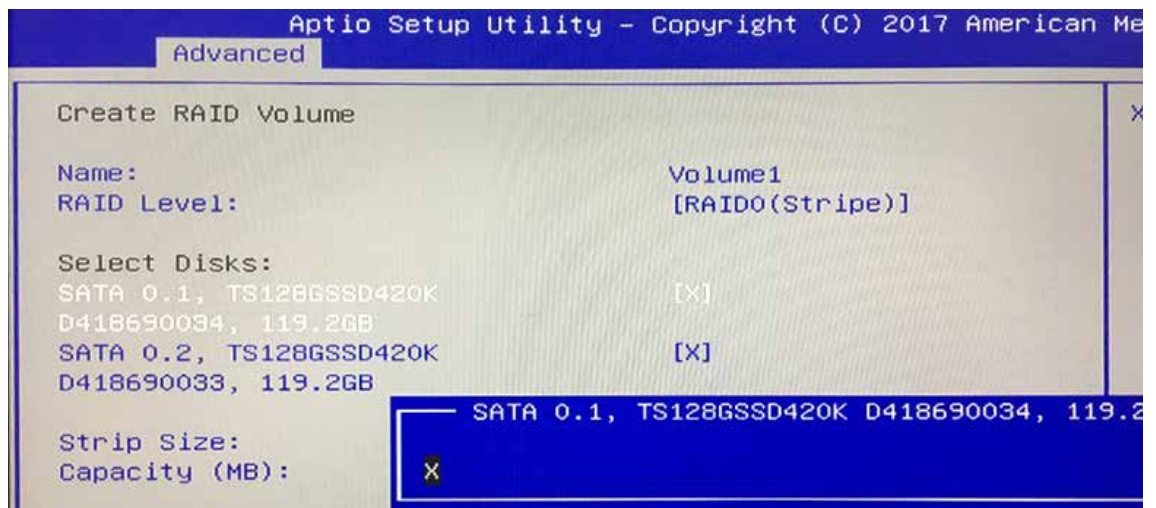

C.2 OS Installation

The system is featured with one M.2 key B, one M.2 key M for NVME, one mSATA slot, and including two internal SATA.

We used SATA for Windows 10 OS installation as an example.

C.3 To Install All Device Drivers of the System

The instructions are as follows :

1. Install Chipset driver
2. Install Network driver
3. Install ME driver (if available)
4. Install Audio driver
5. Install VGA driver

C.4 To Install "Intel Rapid Storage Technology" Software

You can get the software on driver CD.

Also, you can find the latest information and software directly from Intel's website.

http://www.intel.com/p/en_US/support/highlights/chpsts/imsm

The RAID environment has been done if you completed the steps above.

C.5 To Insert SATA HDD for RAID 1

Please note, you can use two SATA ports for SATA HDD, except for mSATA slot.

C.6 To Create RAID Volume on "Rapid Storage Technology" Software

The system is featured with two SATA HDD's for RAID volume, so there are two options to choose on this page. Let's take RAID 1 as an example, select "RAID 1".



C.7 Disk Management : Partition the Disk

After RAID 1 volume is created, you can see the figure of SATA device allocation.

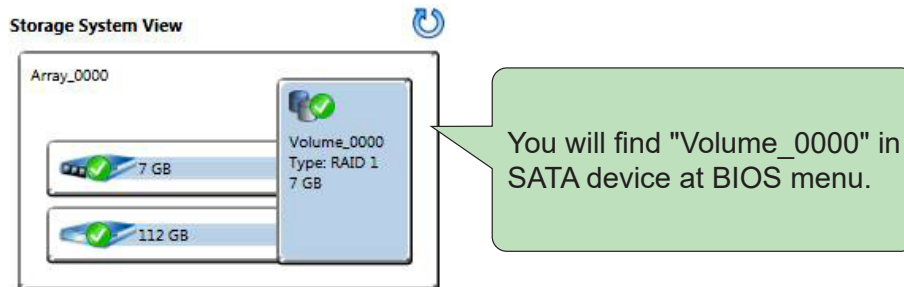

To start disk management tool, select "initialize disk".

Then add "Logical Device" for Windows access.

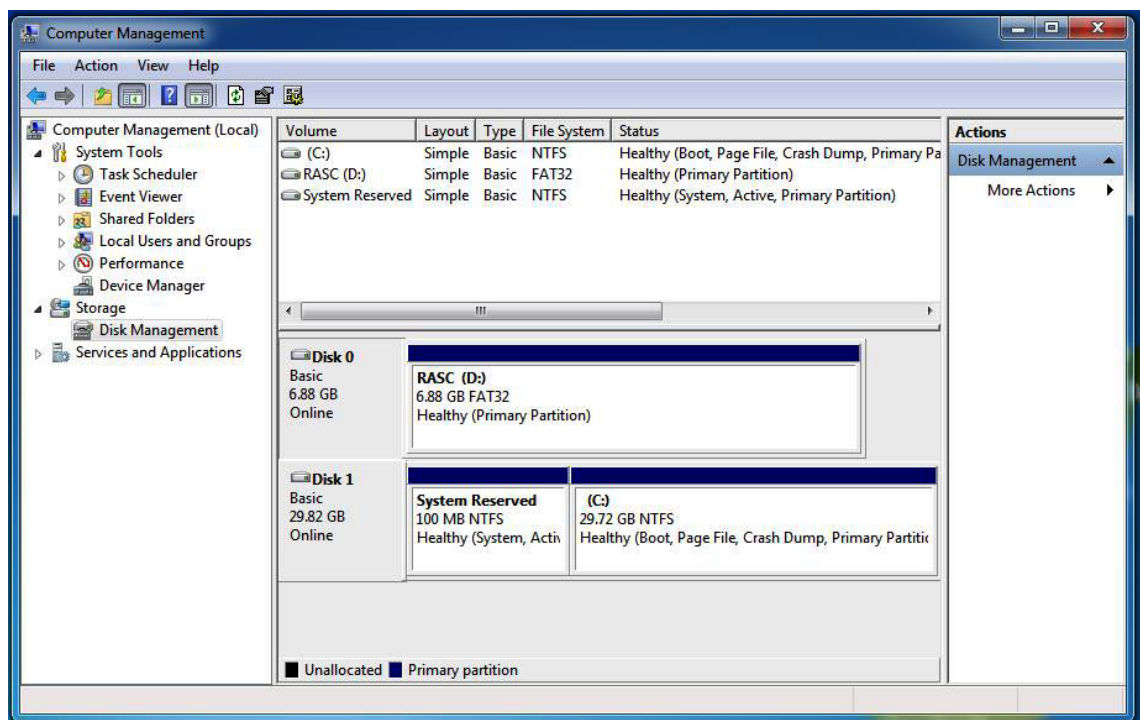

C.8 If One SATA HDD on RAID Volume is Out-of-use

After RAID 1 volume is created, you can see the figure of SATA device allocation.

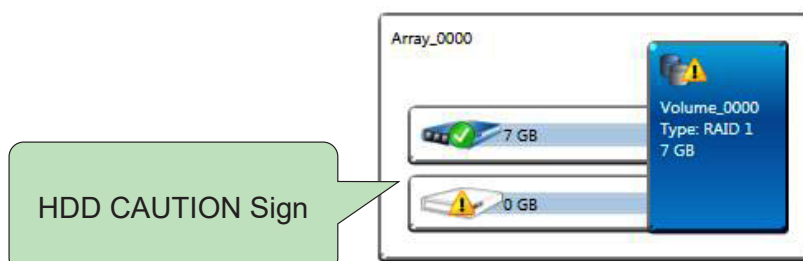

C.9 Recovery and Auto Re-build When Using the SAME RAID HDD

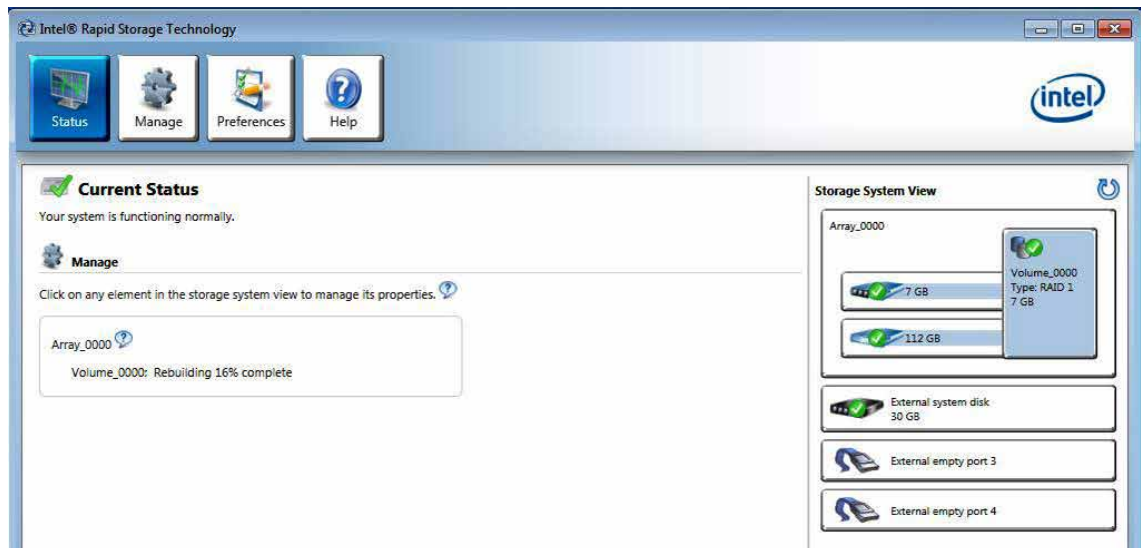

C.10 Recovery and Auto Re-build When Using DIFFERENT RAID HDD

A warning will pop-up to ask you if the disk is not a member of the original RAID volume.

If you press "Rebuild", it will replace the broken SATA HDD to the last SATA HDD of RAID volume.

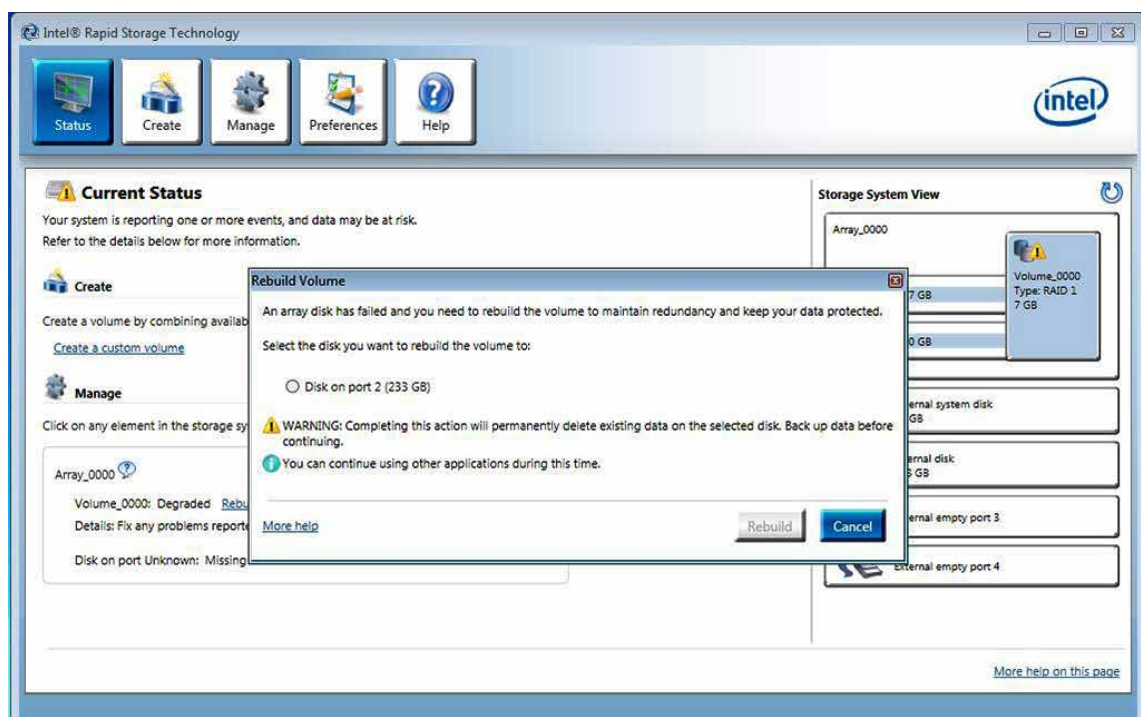

D

APPENDIX D : Power Consumption

Testing Board	IVX-1000
RAM	32GB * 2
USB-1	USB Micsoft Wired Keyboard 600
USB-2	USB Mouse HP G1K28AA
USB-3	USB Flash Transecnd 3.0 8GB
USB-4	USB Flash Transecnd 3.0 8GB
SATA 0	Transcend SATA SSD420 128GB
SATA 1	Seagate HDD 500GB
LAN1 (i219)	1.0 Gbps
LAN2 (i226-IT)	2.5 Gbps
LAN3 (i226-IT)	2.5 Gbps
LAN4 (i226-IT)	2.5 Gbps
LAN5 (i226-IT)	2.5 Gbps
LAN6 (i226-IT)	2.5 Gbps
LAN7 (i226-IT)	2.5 Gbps
LAN8 (i226-IT)	2.5 Gbps
LAN9 (i226-IT)	2.5 Gbps
LAN10 (i226-IT)	2.5 Gbps
Graphics output	HDMI
Power plan	Balance(Windows10 Power plan)
Power Source :	Chroma 62006P-100-25
Test Program-1	BurnInTest
Test Program-2	FurMark

D.1 Intel® Core i7-12700TE 1.40 GHz (25M Cache, up to 4.60 GHz)

Power on and boot to Win 10 (64-bit)

CPU	Power Input	Standby Mode		Power on and boot to Win 10 (64-bit)			
		Max Current	Max Consumption	Sleep Mode		Idle status CPU usage less 3%	
				Max Current	Max Consumption	Max Current	Max Consumption
Intel® Core i7-12700TE	16V	0.559A	08.95W	0.653A	10.45W	1.778A	28.44W
Intel® Core i7-12700TE	24V	0.383A	09.19W	0.452A	10.84W	1.313A	31.50W
Intel® Core i7-12700TE	36V	0.252A	09.05W	0.293A	10.56W	0.781A	28.12W
Intel® Core i7-12700TE	100V	0.097A	09.67W	0.112A	11.23W	0.324A	32.44W

CPU	Power Input	Power on and boot to Win 10 (64-bit)			
		Run 100% CPU usage without 3D		Run 100% CPU usage with 3D	
		Max Current	Max Consumption	Max Current	Max Consumption
Intel® Core i7-12700TE	16V	4.094A	65.50W	4.470A	71.51W
Intel® Core i7-12700TE	24V	2.462A	59.08W	2.933A	70.40W
Intel® Core i7-12700TE	36V	1.608A	57.88W	1.958A	70.49W
Intel® Core i7-12700TE	100V	0.553A	55.28W	0.690A	69.01W

D.2 Intel® Core i9-12900E 2.30 GHz (30M Cache, up to 5.00 GHz)

Power on and boot to Win 10 (64-bit)

CPU	Power Input	Standby Mode		Power on and boot to Win 10 (64-bit)			
				Sleep Mode		Idle status CPU usage less 3%	
		Max Current	Max Consumption	Max Current	Max Consumption	Max Current	Max Consumption
Intel® Core i9-12900E	16V	0.569A	09.11W	0.659A	10.55W	1.851A	29.62W
Intel® Core i9-12900E	24V	0.390A	09.35W	0.437A	10.48W	1.177A	28.25W
Intel® Core i9-12900E	36V	0.247A	08.90W	0.291A	10.49W	0.804A	28.93W
Intel® Core i9-12900E	100V	0.097A	09.70W	0.114A	11.36W	0.295A	29.53W

CPU	Power Input	Power on and boot to Win 10 (64-bit)			
		Run 100% CPU usage without 3D		Run 100% CPU usage with 3D	
		Max Current	Max Consumption	Max Current	Max Consumption
Intel® Core i9-12900E	16V	3.508A	56.13W	6.191A	99.06W
Intel® Core i9-12900E	24V	2.078A	49.87W	4.123A	98.94W
Intel® Core i9-12900E	36V	1.398A	50.33W	2.650A	95.40W
Intel® Core i9-12900E	100V	0.525A	52.50W	0.979A	97.90W

D.3 Intel® Core i3-13100E 3.30 GHz (12M Cache, up to 4.40 GHz)

Power on and boot to Win 10 (64-bit)

CPU	Power Input	Standby Mode		Power on and boot to Win 10 (64-bit)			
				Sleep Mode		Idle status CPU usage less 3%	
		Max Current	Max Consumption	Max Current	Max Consumption	Max Current	Max Consumption
Intel® Core i3-13100E	16V	0.571A	09.13W	0.663A	10.61W	1.652A	26.44W
Intel® Core i3-13100E	24V	0.383A	09.20W	0.451A	10.82W	1.118A	26.83W
Intel® Core i3-13100E	36V	0.247A	08.90W	0.293A	10.56W	0.749A	26.96W
Intel® Core i3-13100E	100V	0.097A	09.67W	0.112A	11.22W	0.268A	26.81W

CPU	Power Input	Power on and boot to Win 10 (64-bit)			
		Run 100% CPU usage without 3D		Run 100% CPU usage with Furmark	
		Max Current	Max Consumption	Max Current	Max Consumption
Intel® Core i3-13100E	16V	4.904A	78.46W	5.292A	84.67W
Intel® Core i3-13100E	24V	3.141A	75.39W	3.341A	80.18W
Intel® Core i3-13100E	36V	2.041A	73.48W	2.246A	80.85W
Intel® Core i3-13100E	100V	0.725A	72.46W	0.781A	78.12W

D.4 Intel® Core i9-12900E Add MXM T1000 Graphics Card

Power on and boot to Win 10 (64-bit)

CPU	Power Input	Standby Mode		Power on and boot to Win 10 (64-bit)			
				Sleep Mode		Idle status CPU usage less 3%	
		Max Current	Max Consumption	Max Current	Max Consumption	Max Current	Max Consumption
Intel® Core i9-12900E	16V	0.563A	09.00W	0.646A	10.34W	2.925A	46.80W
Intel® Core i9-12900E	24V	0.384A	09.22W	0.431A	10.35W	1.834A	44.02W
Intel® Core i9-12900E	36V	0.249A	08.95W	0.281A	10.12W	1.216A	43.78W
Intel® Core i9-12900E	100V	0.080A	07.98W	0.108A	10.78W	0.420A	42.00W

CPU	Power Input	Power on and boot to Win 10 (64-bit)			
		Run 100% CPU usage without 3D		Run 100% CPU usage with Furmark	
		Max Current	Max Consumption	Max Current	Max Consumption
Intel® Core i9-12900E	16V	6.039A	96.62W	8.622A	137.94W
Intel® Core i9-12900E	24V	3.968A	95.23W	5.776A	138.63W
Intel® Core i9-12900E	36V	2.632A	94.74W	3.735A	134.47W
Intel® Core i9-12900E	100V	0.926A	92.55W	1.288A	128.79W

D.5 Intel® Core i7-12700TE Add MXM RTX 3000 Graphics Card

Power on and boot to Win 10 (64-bit)

CPU	Power Input	Standby Mode		Power on and boot to Win 10 (64-bit)			
				Sleep Mode		Idle status CPU usage less 3%	
		Max Current	Max Consumption	Max Current	Max Consumption	Max Current	Max Consumption
Intel® Core i7-12700TE	16V	0.600A	09.60W	0.710A	11.36W	3.300A	52.80W
Intel® Core i7-12700TE	24V	0.408A	09.79W	0.478A	11.46W	2.202A	52.85W
Intel® Core i7-12700TE	36V	0.263A	09.48W	0.312A	11.24W	1.444A	51.99W
Intel® Core i7-12700TE	100V	0.102A	10.20W	0.118A	11.84W	0.501A	50.06W

CPU	Power Input	Power on and boot to Win 10 (64-bit)			
		Run 100% CPU usage without 3D		Run 100% CPU usage with Furmark	
		Max Current	Max Consumption	Max Current	Max Consumption
Intel® Core i7-12700TE	16V	5.497A	87.95W	9.268A	148.29W
Intel® Core i7-12700TE	24V	3.547A	85.12W	6.054A	145.30W
Intel® Core i7-12700TE	36V	2.301A	82.84W	3.956A	142.42W
Intel® Core i7-12700TE	100V	0.801A	80.09W	1.387A	138.66W

E

APPENDIX E : Supported Memory & Storage List

E.1 Supported Memory List

Testing Board	IVX-1000
Memory Test	MemTest86 V8.4
BurnInTest	V9.2

Tset Item

Channel	Memory Test	Burn In	Flash BIOS	Remove Battery
*2	PASS	PASS	PASS	PASS
*1 (Socket 1)	PASS	PASS	N/A	PASS
*1 (Socket 2)	PASS	PASS	N/A	PASS

E.2 Supported Non-ECC Memory List

Brand	Info	Test Temp. (Celsius)
TEAMGROUP 48G DDR5 5600 SO-DIMM	TE48GFSXV2TH	25°C
		25°C
Goldkey 32G DDR5 4800 SO-DIMM	NMSO532F81-4800JA0C	25°C
		25°C
SLLINK 32G DDR5 4800 SO-DIMM	J5BGSH2G8A4FC	25°C
		25°C
SMART 32G DDR5 4800 SO-DIMM	SR4G6SO5285-SB	25°C
		25°C

E.3 Supported ECC Memory List

Brand	Info	Test Temp. (Celsius)
TEAMGROUP 48G DDR5 5600 SO-DIMM	TE48GFSXV2TH	25°C
		25°C
Goldkey 32G DDR5 4800 SO-DIMM	NMES532F81-4800JA0C	25°C
		25°C
SMART 32G DDR5 4800 SO-DIMM	SR4G7SO5285-SB	25°C
		25°C
SLLINK 32G DDR5 4800 SO-DIMM	J5BGDH2G8A4XC	25°C
		25°C

E.4 Supported Storage Device List

Type	Vendor	Model	Capacity
mSATA	Kingston	SUV500MS	128GB
SATA HDD	Seagate	SDC001	500GB
SATA SSD	Apacer	AS340X	120GB
	SMART	FDMP8960GTCXA111	960GB
	MEMXPRO	M3A MI3MA1212802WN	128GB
	Transcend	TS128GSSD420K	128GB
		TS128GSSD230S	128GB
	Kingston	SHFS37A	240GB
	Innodisk	2.5" SATA SSD 3TE4 DES25-A28M41BW1DC-H03	128GB
2.5" SATA SSD 3TG2-P DGS25-64GD81BC1QC		64GB	
M.2 PCIe SSD	Toshiba	KXG50ZNV512G	512GB
	Kingston	SA2000MB	250GB
	SAMSUNG	970 EVO PLUS MZ-V7S250	250GB
		980 EVO PRO MZ-V8P250BW	250GB
	INTEL	760P SSDPEKKW128G8	128GB
	SMART	FDMP8960GTCXA111	960GB

** If more help is needed, please contact Vecow Technical Support.**



For further support information, please visit www.vecow.com

This document is released for reference purpose only.

All product offerings and specifications are subject to change without prior notice.

No part of this publication may be reproduced in any form or by any means, electric, photocopying, or recording, without prior authorization from the publisher.

The rights of all the brand names, product names, and trademarks belong to their respective owners.

© Vecow Co., Ltd. 2024. All rights reserved.